

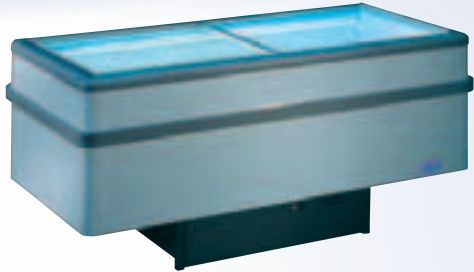

PRACTOR

PRACTOR Measurements



PRACTOR

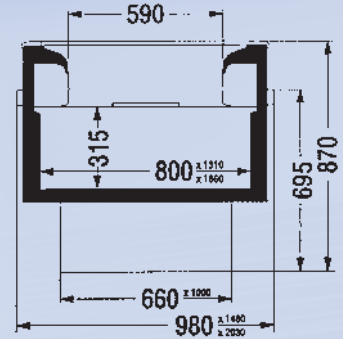

PRACTOR Technical Data

Model	Temperature range (°C)	Volume (ltr.)	Net weight (kg)	Dimensions (mm)			Crated dimensions (mm)			Crated weight (kg)	Transport		Application
				width	depth	height	width	depth	height		Truck (13,6)	40'cont.	
1585	-18...-23	330	137	1480	980	870	1540	1090	1130	157	34	30	
1585G			158			890				178			
2085		470	176	2030		870	2090	206	24	22			
2085G			193			890		220					

Islands · Wallsides
Temp.: - · +/-