

SMM10

SMM60
(SMM10 with a can top)SMM70
(SMM10 with a bottle top)

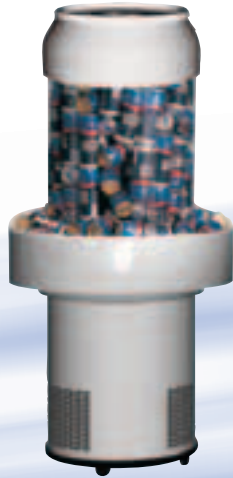

SMM20



SMM30



SMM40

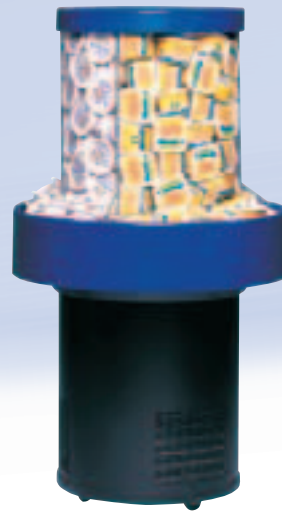

SMM50

SMM10 / SMM50

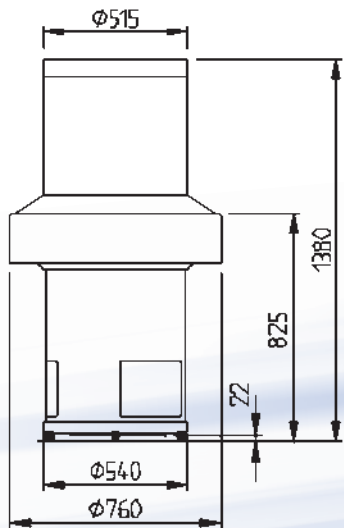

SMM20

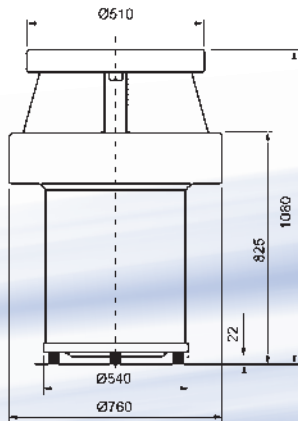



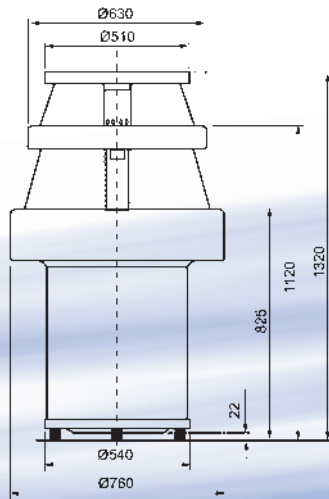

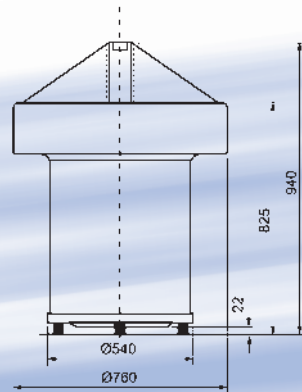

SMM30



SMM40



SALES MAKER Technical Data

Model	Temperature range (°C)	Volume (ltr.)	Net weight (kg)	Dimensions (mm)			Capacity (pcs)		Crated dimensions (mm)			Crated weight (kg)	Transport		Application	
				width	depth	height	0,33 l can	0,5 L Pet bottle	width	depth	height		Truck (13,6)	40' cont.		
SMM10	0...+4	150	52	760	760	1380	220	144	780	810	1520	60	48/96*	45/90**		
SMM20	0...+8	90				1080	n/a	n/a			1200		96	45/90***		
SMM30	0...+8 (lower shelf)	160	52			1320	n/a	n/a			1520	60	48	45		
	+14...+15 (middle shelf)					940	n/a	n/a			1100					57
SMM40	0...+8	60	50			1380	n/a	n/a			1520	64	48/96*	45/90**		
SMM50	0...+4	150	56			-	220	144			-	-	-	-	-	
SMM60		150	-			-	220	144			-	-	-	-	-	
SMM70		150	-	-	220	144	-	-	-	-	-					

*fully mounted/half mounted | **standard cont./half mounted in HC cont. | ***standard cont./HC cont.