



Carrier

A United Technologies Company

Presenting
Communicating
Preserving
Ultrafreshness





Improve the freshness climate, and win customers.

Self-Serve Cut Flowers · Fruit & Vegetables, loose

Fruit & vegetables, a food line in the “ultrafreshness” category, is one of the product groups with the biggest opportunities. Along with the “lead green produce,” kitchen-ready products such as cleaned vegetables, herbs, prepared fruit, ready-to-eat salads, sushi, fresh pasta, smoothies, as well as cut flowers belong to the dynamically expanding “ultrafresh” product segment. It stands for competitive value creation and image projection. The continuing growth in the fresh food sector is driven and supported by social trends focusing on health, wellness, organic foods and vitality. As well, food safety has become more of a major concern among consumers, producers and retailers.

But to score points with fruits & vegetables and other fresh foods, retailers have to offer their customers but the best in freshness and quality. If this is not provided, the consumer will likely leave the store – for good. While for the consumer, deterioration in produce quality means loss of flavor and decreased nutritional value, for the retailer it means product weight loss and a shorter shelf life, impacting sales and profits in the form of spoilage write-offs.

No gaps in the refrigerated multideck

For successful retailing of temperature-sensitive products, not only is a fast and efficient supply chain needed but also a professional and quality-preserving presentation at the point of sale. This allows the products to remain on display for longer in the refrigerated multideck, which can contribute to increased sales and better product availability. Out-of-stock situations can also be avoided as a result. Sustainable logistics is possible and product return rates can be significantly decreased. And another advantage: the in-store handling costs can be significantly reduced as the need to return produce to the cold room in the evenings can be eliminated.

Provide better freshness with refrigeration

For the vast majority of fresh produce the vital refrigeration ceases when the merchandise is placed on display in the retail store. The “dry merchandising” approach still predominates 90% of the time. At the same time, many innovative products such as fresh cuts and smoothies have been added to the fresh food range. For these, too, new merchandising concepts are needed.

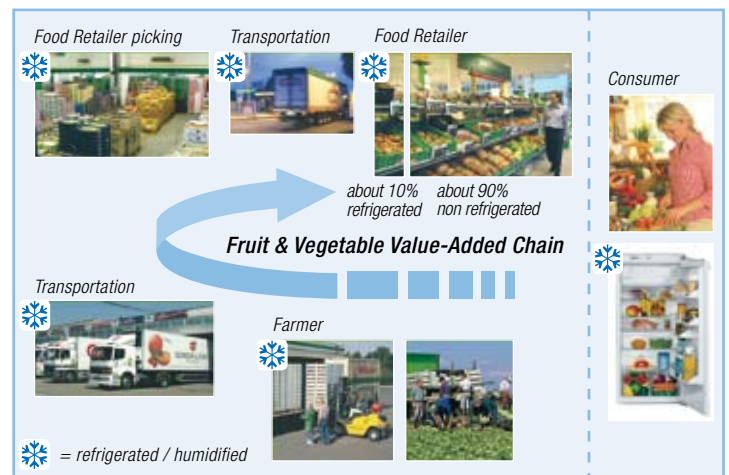

Fresh produce has a long journey before reaching the consumer's fridge. A departure from the refrigeration chain, for example through “dry merchandising” in the sales area, puts the “living” produce under heavy stress and results in deterioration and ultimately spoilage.

Carrier meets these challenges and trends in the food retail trade with an innovative series of refrigerated multidecks based on the new NC product family. This refrigerated multideck range is designed without a ceiling (NC = no ceiling) and is characterized by great flexibility in the interior fittings. Whether wall or center-sited, with trolleys or shelves, with humidification or without: the new NC refrigerated multidecks can be used for all fresh food lines – loose or packaged – and integrate into modern store architecture.



/packaged · Herbs · Convenience Salads, Dressings · Fresh Cut Fruit · Smoothies · Fresh Pasta & Pizzas, Sauces · Sandwiches & Baguettes · Sushi

Air humidified = stay fresh longer

Whether radishes, green salad or bunched carrots, a combination of refrigeration and humidification is necessary for perfect merchandising of loose produce. By contrast with refrigeration alone, which slows down the aging process, the purpose here is to reduce wilting and product weight losses. All parameters of the merchandising system must be matched to the sensitive product – and that's a matter of know-how. In particular, it's important that no moisture should form in or on the product or under the trolley.

Carrier has developed a new, professional ultrasonic humidifying system delivering high performance and quality. The units are easy to clean and provide an excellent standard of hygiene.



In the professional ultrasonic humidifying system an aerosol mist formed of tiny water droplets is captured by the current of cold air and drifts around and through the fresh produce, preserving its quality.

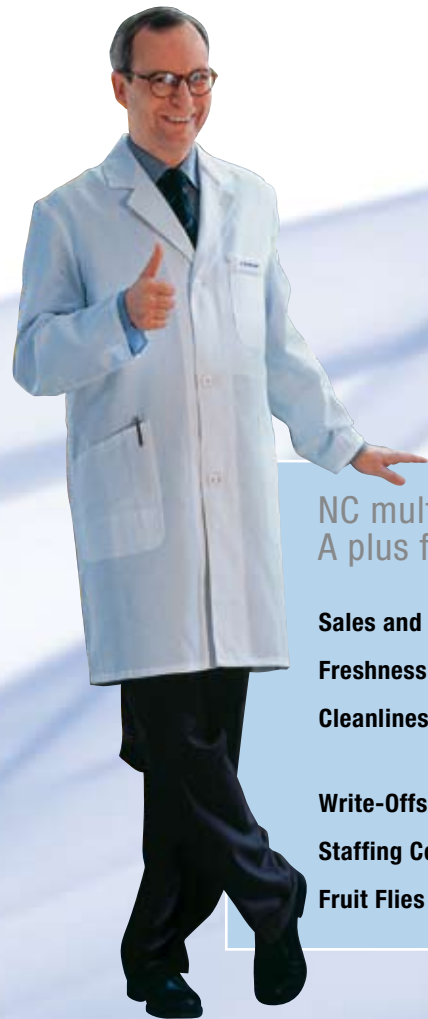

NC multideck technology – A plus for fruit & vegetables

Sales and ROI



Freshness



Cleanliness and Hygiene



Write-Offs for Spoilage



Staffing Costs



Fruit Flies





Monaxis NC system

More flexibility in the fresh food department

Less cabinet, more merchandising space: with optimal refrigeration and a multitude of different display fittings the Monaxis NC system provides a neat setting for the lead product group “fruit & vegetables.” There’s practically no ceiling, so the produce compartment is wide open to the customer’s view.

A diverse range of fittings can be combined to practically meet any requirement from the base, display decks, stepped display shelves in slim-line design, and hinged racks, roll-in boxes and pallets. An intermediate panoramic thermo pane wall can be used to create temperature zones to suit different product groups.



Monaxis 80-NCH

With a temperature range of 0-12 °C, the Monaxis NC is an ideal merchandiser for a wide variety of fruit and vegetables. Reliable refrigeration through air conduction that operates like a “waterfall” makes the Monaxis NC system particularly suitable for displaying sensitive fresh convenience products.

Attractive accessory packages are optionally available, like the ultrasonic humidifying system (in combination with trolleys), slim-line shelves, air-ducted shelves for system containers, external lighting, mirrored glass tops with integrated lighting, etc.



Multiplexing of Monaxis NCH and NC

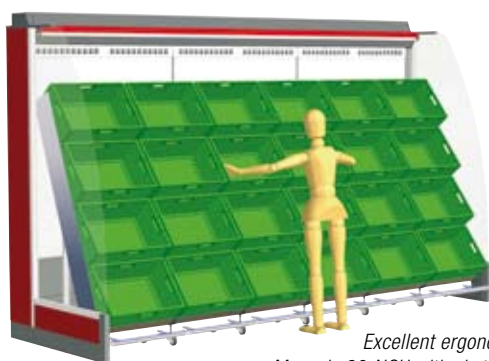

Excellent ergonomics: Monaxis 80-NCH with six trolleys

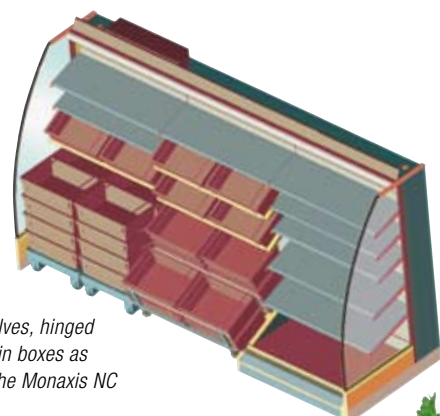

Air-ducted shelves, hinged racks and roll-in boxes as illustrated on the Monaxis NC





Mirado NC system

Providing freshness late into the evening

With the new Mirado NC system it is even easier to bring ultrafresh food selections into customer focus. Whether on trolleys or slim-line display shelves, the Mirado NC system can present uncompromising freshness, quality and variety till late in the evening.

With a low cabinet height of 1600 mm the Mirado NC is perfectly suited for center siting. Arranged as a gondola, this semi-vertical solution offers maximum productivity per unit floor space.

Ultrafresh products – ideally presented – in different temperature ranges of 0-4 °C or 4-12 °C. This is made possible, for example, by the use of a panorama intermediate wall which can be fitted optionally between the different shelving sections.

Attractive accessory packages are optionally available, like trolleys in different depths and a customized number of container places, slim-line display shelves in combination with various merchandise front heights, external lighting, hook rails, mirrored glass tops, ultrasonic humidifying system and pricing systems for A4/A5 formats.

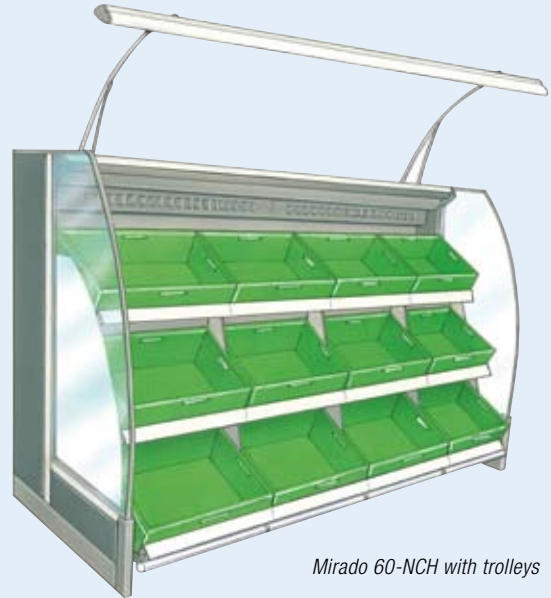

Mirado 60-NCH with trolleys



Mirado 63-NC with shelves

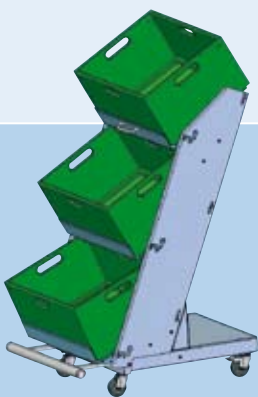

*Trolleys for
Mirado 60-NCH*

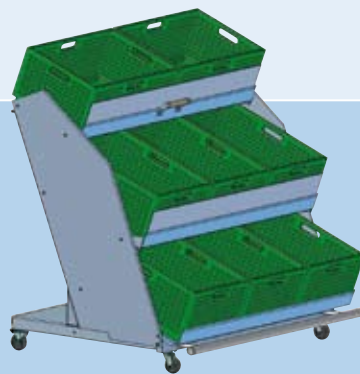

*Trolleys for
Mirado 80-NCH*

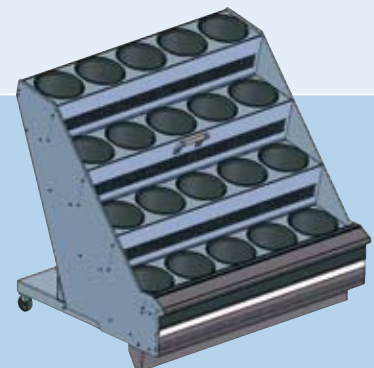

*Trolleys for
cut flowers on Mirado 80-NC*



Morea NC system

Fresh food in the style of an open market

Spaciousness, tidiness and above all atmosphere are the impressions that can be generated with the new Morea NC system. Besides that, the Morea NC offers optimized safety and handling of merchandise. It allows an extremely wide range of produce to be displayed in the style of an open market especially in center-store but also as a wall site with mirrored top and integrated lighting.

Packaged or loose fruit & vegetables and convenience products can be displayed within easy reach alongside one another – with optimized refrigeration and, if necessary, a professional air humidifying system catering for long-lasting freshness.

The new, flexible trolley concept insures easy cleaning and excellent hygiene. Maintenance of the system is revolutionized. The robust trolleys are designed to match Linde's "Evolution5" range of refrigerated merchandisers. High-quality chromium-nickel materials are used in the manufacture of the display shelving and for the more heavily merchandised components of the system.

Attractive accessory packages help generate extra sales, such as trolleys in varying depths and front heights, slim-line shelves, mirrored glass tops, ultrasonic humidifying system, panorama thermopane intermediate wall and pricing systems for A4/A5 formats.



*Morea 106-NCH with mirrored glass top
(Wall siting)*

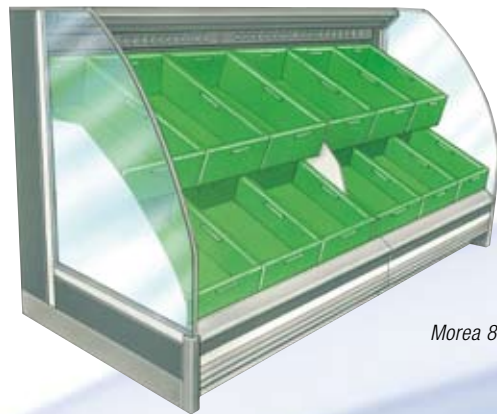

Morea 84-NCH

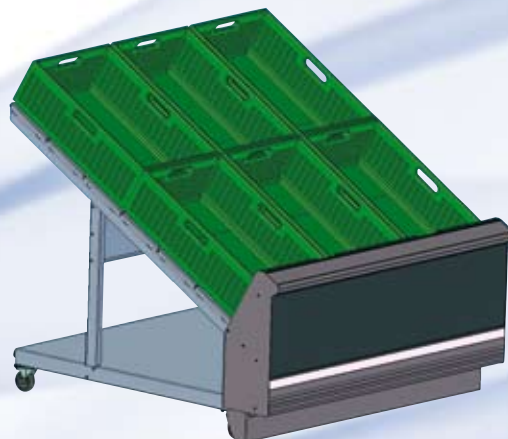

*Trolleys on
Morea 106-NC/NCH*



Basic models in the NC product family

Selected model versions. Further information on the individual NC refrigerated multidecks is available on request.

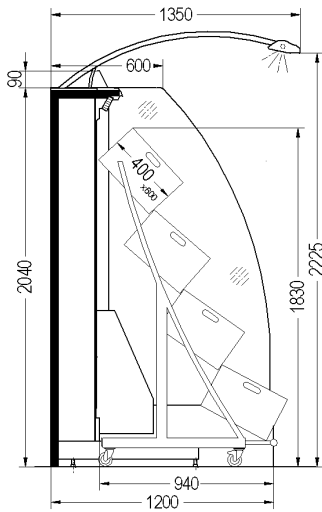

Monaxis 80-NCH with trolleys

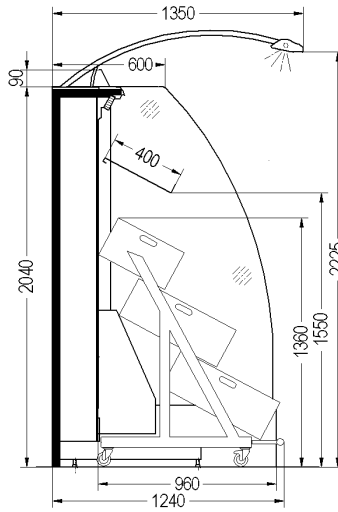

Monaxis 80-NCH with trolleys and one row of shelving

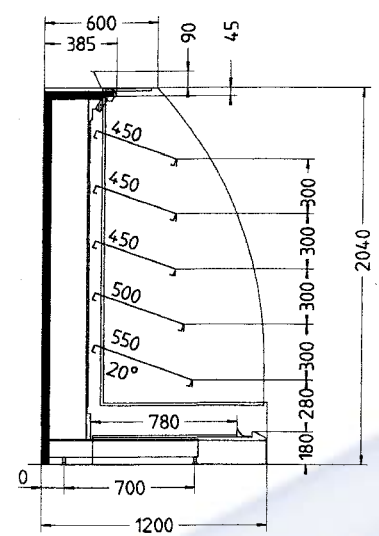

Monaxis 82-NC with shelving

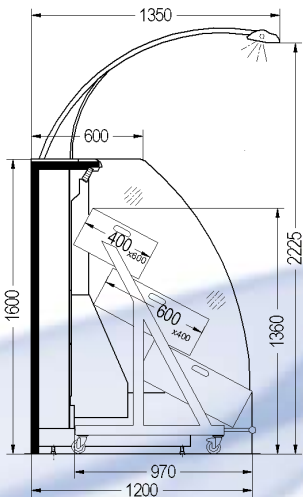

Mirado 80-NCH with trolleys and external lighting*

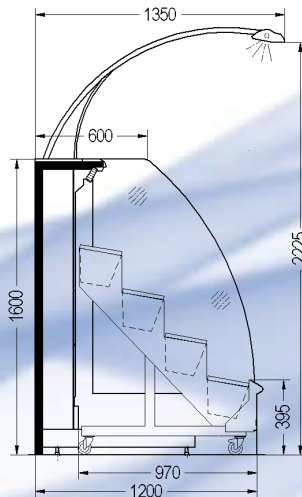

Mirado 80-NC with trolleys for cut flowers

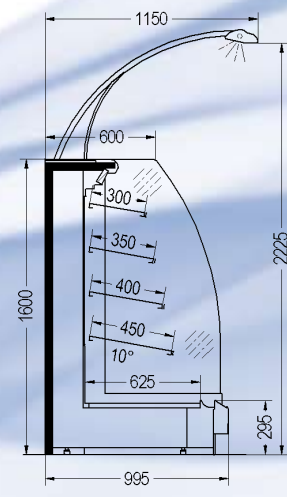

Mirado 63-NC with shelving and external lighting*

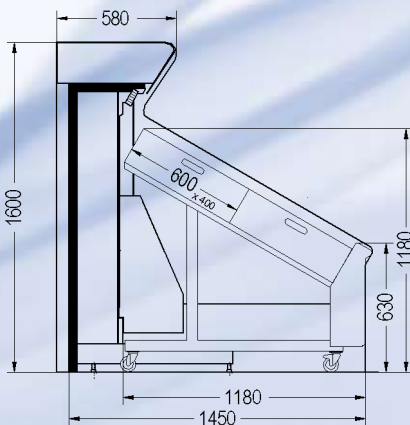

Morea 106-NCH with trolleys and mirrored glass top*

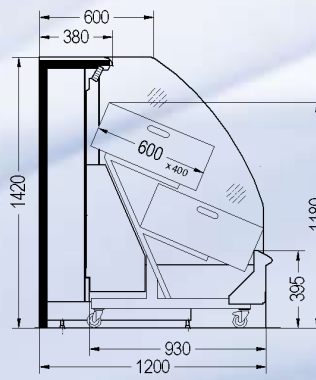

Morea 84-NCH with trolleys

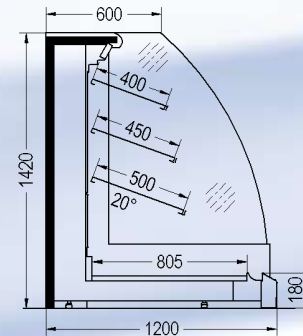

Morea 82-NC with shelving

NC = no ceiling
H = humidified
*optional



Think system – master energy

Smart systems use energy wisely, where needed, when required.

Based on this understanding we offer solutions combining “energy, efficiency and ecology”.

This stands for energy savings over the entire life cycle, sustained performance in temperature quality and food safety, and significant carbon footprint reduction. On this we focus our energy.

Increasing sales is one of your benefits.

We provide more: sustainable refrigeration with state-of-the-art solutions.



Carrier

A United Technologies Company

Carrier Kältetechnik Deutschland GmbH
Sürther Hauptstraße 173
50999 Cologne · Germany
www.carrier-refrigeration.de