

**Ultra-fresh sales**  
of cut flowers



Developing and enhancing ultra fresh presentation with the new Mirado-NC system.

### Advantages at a glance

- Reduced product loss of cut flowers
- Increased competitiveness
- Strong-selling display of merchandise
- Diversity and quality enhancement
- Increased sales
- No need to move flowers back to the cold room, which reduces handling costs
- Simplified care, extremely easy system maintenance
- Impeccable cleanliness and hygiene
- Easy cleaning

### Product features

- Suitable for temperature-assured presentation of cut flowers
- Trolleys with 4 display levels for up to 20 flower buckets
- Optimized cooling air flow
- Extra large evaporator surface for extra high air humidity
- Center, stand-alone, or wall siting

### Accessories

- External lighting
- Trolleys
- Panoramic glazed end-walls
- Glazed intermediate wall to create temperature zones to suit different product displays
- Mirrored top on request

One merchandiser concept – the solution for your cut flowers display

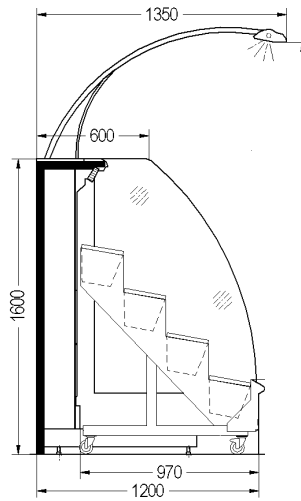

Mirado 80-NC for cut flowers

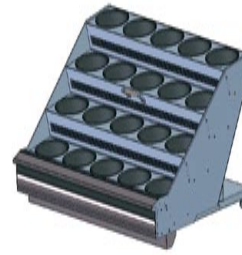

Trolley for cut flowers

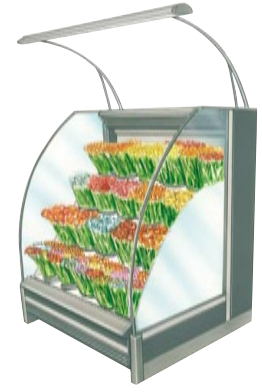

Mirado 80-NC for cut flowers

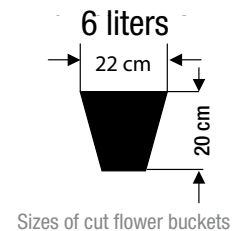
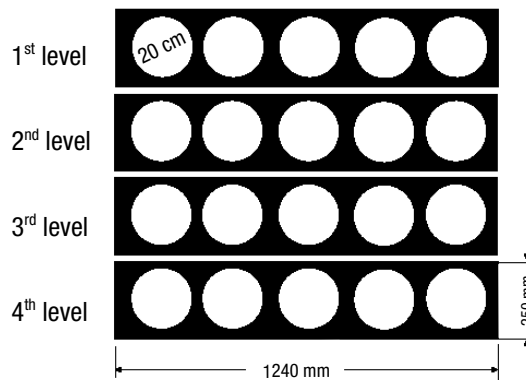

Sizes of cut flower buckets

### Technical Data

Mirado-NC system for cut flowers				NC = no ceiling	
Lengths without endwall	(mm)	1250	1875	2500	3750
Number of buckets	(6 liters)	20	30	40	60
Temperature range	(°C)	0 - 12			
Number of trolleys	(qty)	1	1*	2	3

\*with trolley in special length