

**Low energy
consumption, high
temperature safety**



Think system – master energy

Monaxis GD. e^{*}cube

- New multideck in the “Evolution5” range with frameless insulating glass doors, recommended for all temperature-sensitive products
- High energy savings and temperature safety
- High transparency of goods due to frameless doors
- Reduced influence of radiation
- Reduction of ambient perturbations
- Reduced operating costs
- Avoidance of so-called “cold alleys” leading to increased customer comfort
- Reduced refrigeration load, smaller multicompressor packs, smaller piping diameters

Other e^{*}cube energy saving components

- ECM fan motors

e^{*}cube accessories

- LED canopy lighting
- LED display shelf lighting

Total e^{*}cube saving potentials

- Refrigeration load (requirement) max. 42%
- Total energy consumption max. 49%

Standard accessories

- CO₂ evaporator
- Electronic expansion valves
- T5 lighting with electronic ballasts
- UA 300 refrigeration controller



Technical data

Monaxis 83-GD. e [*] cube	(Modules)	125	250	375
Lengths incl. endwalls (40 mm each)	(mm)	1330	2580	3830
Temperature ranges	(°C)			
3		2-4	2-4	2-4
4		0-2	0-2	0-2
5		-1/+1	-1/+1	-1/+1
6		-2/0	-2/0	-2/0
Display area	(m ²)			
Monaxis 83-GD.		3.25	6.55	9.80
Monaxis 83-GD.L		4.75	7.80	11.80

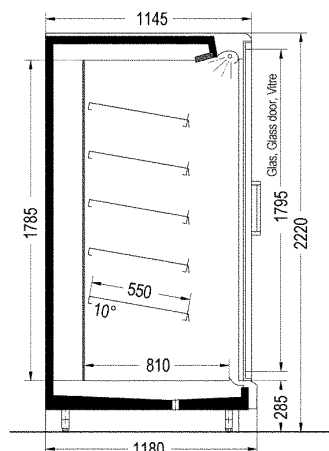

Monaxis 83-GD.C6 L e^{*}cube

