

Freshness you can see

Refrigerated island AIB..45 S

AIB type islands are wide refrigerated islands for small shop layouts that have a classic design. They allow ultrafresh products to be presented with a strong focus on sales even in small floor areas. What is more, they offer an excellent overview of products and a 180 mm high wrap-around window, which guarantees good customer contact.

Accessories

- Partially glazed side walls
- Island insert with illuminated displays
- Sliding glass panels
- Night-covers (for open models)
- Coloured bumpers
- Height-adjustable grid displays and product separator grilles
- Grid covers in stainless steel

Advantages at a glance

- Large presentation area
- Excellent product visibility
- 180 mm wrap-around glazing
- 300 mm stacking height
- Safe, cost-efficient refrigeration technology
- Strong sales-focused presentation of products
- Classic refrigeration island design
- With optional sliding glass panels

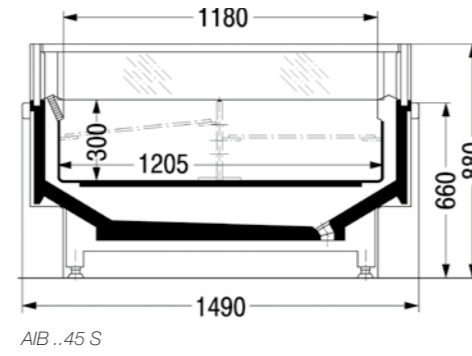

AIB ..45 S



AIB 0645 S

Refrigerated island	AIB ..45 S	
Standard lengths	04	06
Length, excluding side walls	[mm]	2500 3750
Length, including side walls (each 105 mm)	[mm]	2710 3960
Display area	[m ²]	3,0 4,5
Cubic capacity, liters net	[L]	910 1360
Temperature ranges*	[C°]	0 ... 2 / 2 ... 4
Operating voltage	[V/Hz]	230 / 50

* depending on refrigeration machine assignment

Carrier Commercial Refrigeration offices

Austria

Carrier Kältetechnik Austria Ges.m.b.H.
1232 Vienna-Inzersdorf
Phone +43 1 661 04 0

Belgium

Carrier Refrigeration Belgium SA/NV
2627 Schelle
Phone +32 3 231 50 93

China

Carrier Refrigeration System (Shanghai) Ltd.
Shanghai 200003
Phone +86 21 23 06 30 00

Croatia

Carrier Kältetechnik Austria Ges.m.b.H.
Glavna podružnica Zagreb
10000 Zagreb
Phone +385 1 2484 000

Czech Republic

Carrier chladičí technika CZ s.r.o.
190 00 Prague 9
Phone +420 281 095 111

Denmark

Carrier Refrigeration Denmark A/S
8350 Hundslund
Phone +45 86 55 02 55

Finland

Carrier Kylmätalo Oy
04601 Mäntsälä
Phone +358 19 52 29 200

France

Carrier Refrigeration Distribution France SAS
94100 St Maur des Fossés
Phone +33 1 43 97 61 00

Germany

Carrier Kältetechnik Deutschland GmbH
50999 Cologne
Phone +49 2236 601 01

Greece

Carrier Frigel Apostolou SA
10442 Athens
Phone +30 210 5763950

Hong Kong

Carrier Hong Kong Ltd.
Kowloon
Phone +852 26 94 53 33

Hungary

Carrier Hátéstechnika Forgalmazó
Magyarország Kft./
Carrier Refrigeration Distribution Hungary Ltd.
1037 Budapest
Phone +36 1 437 05 10

India

Carrier Airconditioning and Refrigeration Ltd.
Gurgaon, Harayana 122001
Phone +91 124 482 55 00

Ireland

Carrier Refrigeration Ireland
a branch of Carrier UK Ltd
Dublin 24
Phone +353 1 451 5585

Italy

Carrier Refrigeration Distribution Italy SpA
20090 Buccinasco (Milan)
Phone +39 02 488 675 1

Korea

Carrier Refrigeration Korea
Youngdeungpo-gu, Seoul
Phone +82 2 20 71 51 03

Malaysia

Carrier (Malaysia) Sdn. Bhd.
47610 Subang Jaya, Selangor Darul Ehsan
Phone +603 802 47 77 88

Middle East

Linde Kältetechnik GmbH – (Carrier
Commercial Refrigeration)
Dubai – United Arab Emirates
Phone +971 4 222 5216

Netherlands

Carrier Bedrijfskoeling Nederland B.V.
4104 AW Culemborg
Phone +31 345 544 444

Norway

Carrier Refrigeration Norway AS
0668 Oslo
Phone +47 23 37 58 40

Philippines

Carrier Linde Refrigeration Phils., Inc.
Alabang, Muntinlupa City
Phone +632 775 06 30

Poland

Carrier Chłodnictwo Polska Sp. z o.o.
02-676 Warsaw
Phone +48 22 54 40 100

Russia

Carrier Refrigeration Rus
109240 Moscow
Phone +7 495 933 11 75

Singapore

Carrier Singapore (Pte) Ltd.
Singapore 608926
Phone +65 65 67 55 22

Slovakia

Carrier chladiaca technika Slovakia s.r.o.
949 07 Nitra
Phone +421 377 764 011

Slovenia

Carrier Kältetechnik Austria Ges.m.b.H. –
Podružnica Ljubljana
1000 Ljubljana
Phone +386 1 2425 523

Spain

Carrier Refrigeración Ibérica SA
08036 Barcelona
Phone +34 93 4527 184

Sweden

Carrier Refrigeration Sweden AB
213 76 Malmö
Phone +46 40 664 51 70

Switzerland

Carrier Kältetechnik Schweiz AG
4133 Pratteln
Phone +41 61 816 66 66

Taiwan

Carrier Transicold Pte Taiwan Branch
Taipei
Phone +886 2 28 81 18 00

Thailand

Carrier Linde Refrigeration (Thailand) Ltd.
Bangkok 10510
Phone +66 25 17 20 00

United Kingdom

Carrier Refrigeration UK Ltd.
Oxford OX4 6HQ
Phone +44 1 865 337 700



Carrier

A United Technologies Company

AIB / AIT

Refrigerated/frozen food islands
Ice-cool freshness - guaranteed



Large presentation area
Ergonomically optimized access
Excellent product visibility



Linde

A United Technologies Company

ML-GF-606-GB-1209

Linde

Secure and expand sales

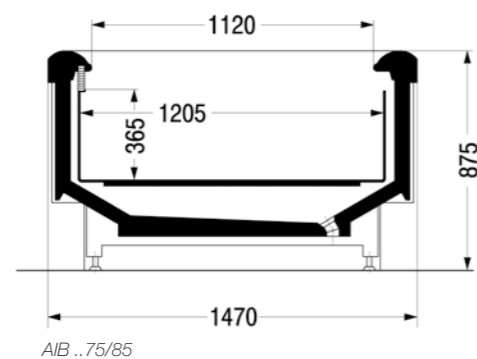

AIB ..75/85

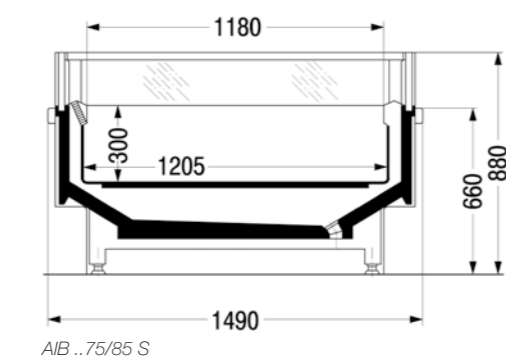

AIB ..75/85 S

Frozen food island AIB..75/85

Frozen food island AIB..75/85 S

The AIB 1.5 m wide frozen food island has been specially designed for shops with a small floor area. A long, open customer contact area presents the goods with a strong focus on sales promotion. A classic island design helps to expand and heighten the profile of chilled goods.

Accessories

- Partially glazed side walls (AIB)
- Single-level or two-level island inserts with illuminated displays
- Handrail lighting (T5 light or LED)
- Energy-saving kit with sliding glass panels (AIB S)
- Height adjustable grid displays and product separation grilles
- Night covers
- Coloured bumpers

Advantages at a glance

- Large presentation area
- 180 mm wrap-around glazing (model: AIB ..75/85 S)
- Stacking height 300 or 365 mm
- Ergonomically optimized access
- Eco-friendly halogen-free insulation
- Energy-saving evaporator system
- Classic frozen food island design

Clear view of the full product range

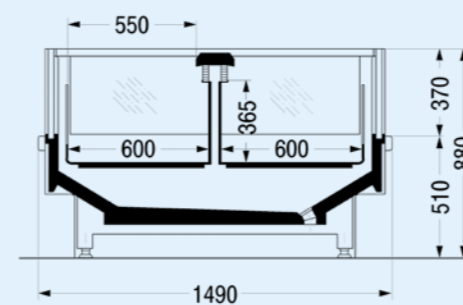

AIB ..75/85 M GH 370

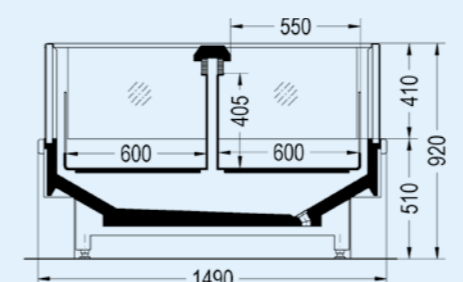

AIB ..75/85 M GH 410

Frozen food island AIB..75/85 M GH 370

Frozen food island AIB..75/85 M GH 410

The optimum dimensions of the AIB..M frozen food island makes perfect use of the shop floor space. A generous wrap-around window allows the products to be seen clearly even at a distance. The ergonomically optimized product area makes it easy for customers to pick and remove products.

Accessories

- Optional 410 mm wrap-around window
- Glazed panoramic side walls
- Island insert with illuminated displays
- Handrail lighting (T5 light or LED)
- Energy-saving kit with glass sliding panels
- Height adjustable grid displays and product separation grilles
- Night covers
- Coloured bumpers

Advantages at a glance

- High product density
- Ergonomically designed, easy-to-reach goods display
- Ice-cool freshness, with a focus on sales promotion
- Good visibility through 370 mm or 410 mm wrap-around glazing
- 360 mm or 410 mm stacking height
- Customer-friendly price labels on the middle rail
- Classic frozen food island design

Frozen foods galore

Frozen food island AIT..75

A feature sure to impress price-conscious customers. An enormous goods volume of around 550 liters per linear meter is one of the strengths of the AIT frozen food island. Designed for shops with limited floor space, this 1.5 m island offers a rugged and classic design.

Accessories

- Night covers
- Island insert, single-level or two-level with illuminated displays
- Height adjustable grid displays and product separation grilles
- Coloured bumpers

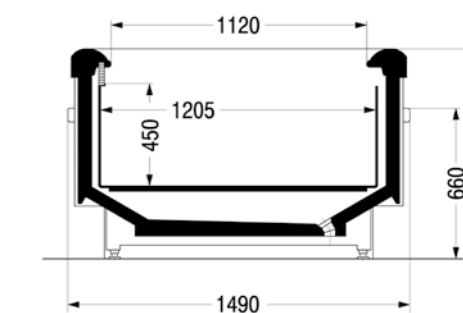

AIT ..75

Advantages at a glance

- Large volume of goods with a small island floor area
- Ergonomically designed, easy-to-reach goods display
- Enormous 450 mm stacking height
- Low energy consumption
- Eco-friendly halogen-free insulation
- Rugged, classic frozen food island design

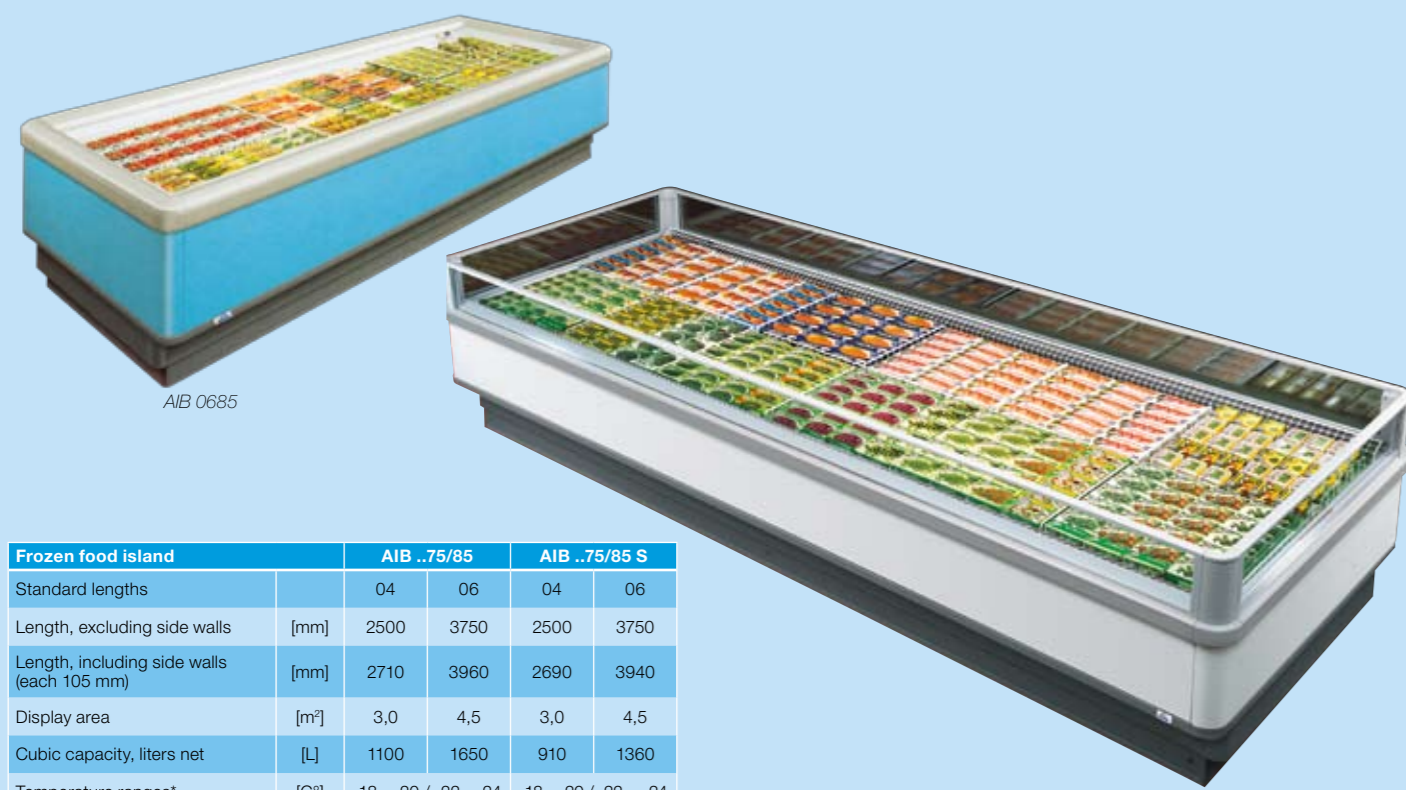

AIB 0685

AIB 0685 S

Frozen food island	AIB ..75/85		AIB ..75/85 S		
Standard lengths	04	06	04	06	
Length, excluding side walls	[mm]	2500	3750	2500	3750
Length, including side walls (each 105 mm)	[mm]	2710	3960	2690	3940
Display area	[m ²]	3,0	4,5	3,0	4,5
Cubic capacity, liters net	[L]	1100	1650	910	1360
Temperature ranges*	[C°]	-18...-20 / -22...-24		-18...-20 / -22...-24	
Operating voltage	[V/Hz]	230 / 50		230 / 50	

* depending on refrigeration machine assignment

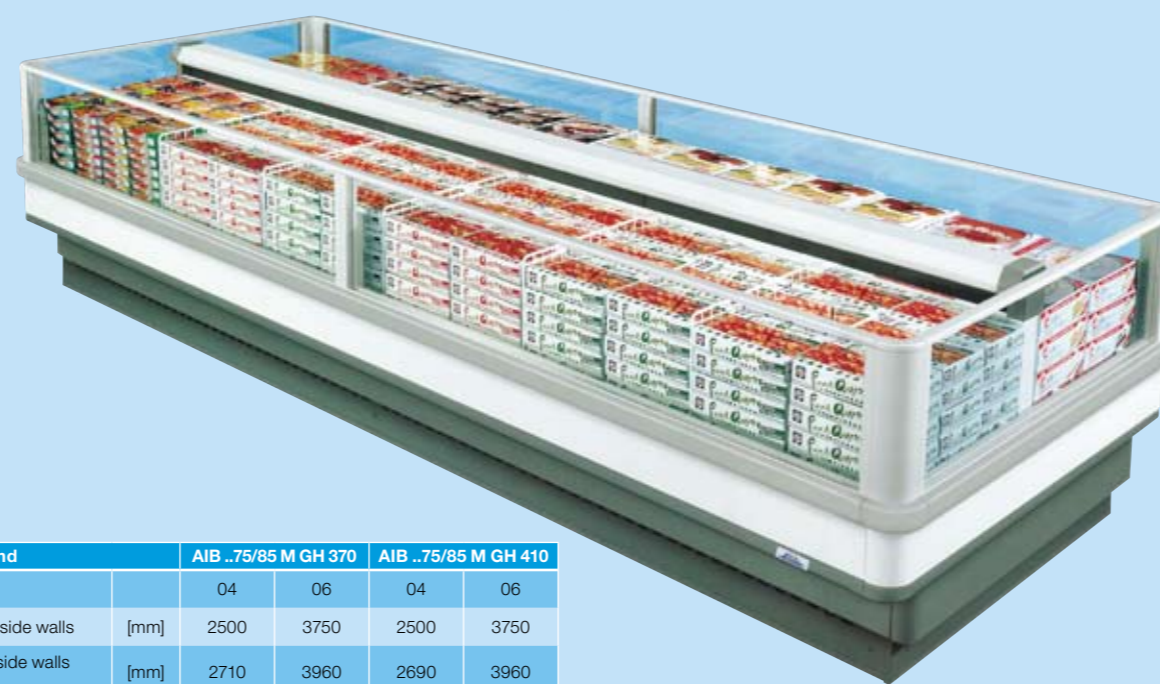

AIB 0685 M GH 370

Frozen food island	AIB ..75/85 M GH 370		AIB ..75/85 M GH 410		
Standard lengths	04	06	04	06	
Length, excluding side walls	[mm]	2500	3750	2500	3750
Length, including side walls (each 105 mm)	[mm]	2710	3960	2690	3960
Display area	[m ²]	3,0	4,5	3,0	4,5
Cubic capacity, liters net	[L]	1080	1620	1215	1823
Temperature ranges*	[C°]	-18...-20 / -22...-24		-18...-20 / -22...-24	
Operating voltage	[V/Hz]	230 / 50		230 / 50	

* depending on refrigeration machine assignment



AIT 0675

Frozen food island	AIT ..75		
Standard lengths	04	06	
Length, excluding side walls	[mm]	2500	3750
Length, including side walls (each 105 mm)	[mm]	2650	3900
Display area	[m ²]	3,0	4,5
Cubic capacity, liters net	[L]	1360	2040
Temperature ranges*	[C°]	-18...-20	
Operating voltage	[V/Hz]	230 / 50	