

# High point in the frozen food program

Velando Frozen Food Vertical

Velando is the vertical frozen food case that falls in line yet stands out. Choreographed to take up position with the other slim members of the Evolution5 troupe, it exhibits the same qualities and standards of style aligned to

contemporary performance. Graceful in pattern and pose, it has a huge product facing area, low base front and lighting that brilliantly plays up any product selection deserving star billing.

*Linde*

# Premiere for open presentation



The Velando frozen food vertical fits seamlessly into the new Evolution5 Range – uniformity of ensemble with front set low from wing to wing. Particularly the modern all-glass version provides brilliant facing. This is supported by typical Linde features

such as an effective lighting concept, door pulls forming a key design element, robust collision bumpers and custom color schemes that stress a store's individuality. The kind of closed presentation that promises a successful opening.



# High-class and more



Velando offers all the space you need to display frozen foods of the higher categories. Generous division of the interior is designed to accommodate plenty of stock. A bigger stocking capacity results in better space productivity. The greater the quantity and variety of merchandise, the stronger is its appeal to customers. Advanced cold air flow distribution and control ensured by energy-saving Linde refrigeration ensures impeccable preservation of quality too.

#### **Staged for fast-moving turnover**

- **Brilliant lighting concept**
- **Maximized product facing area**
- **Increased vertical merchandising height**
- **Greater productivity per unit of floor space**
- **Matched to style of other display cases**



Expansive product facing area with long-range visual attraction

display space  
of it



Frameless all-glass doors



Sturdy base bumper



Digital thermometer

# Putting products in the right light



Proper and effective lighting catches the eye of customers and their fancy too. The lighting concept implemented in Velando is stimulating in every sense. Optimal illumination of the merchandise with T5 high-luminance fluorescent lamps and specially matched reflectors leads to shining sales.

This is where Linde's superior know-how comes in. The brighter the lighting of frozen food displays, the better they need to be shielded from heat generation. There's no more radiant an example of how this is accomplished than Velando.

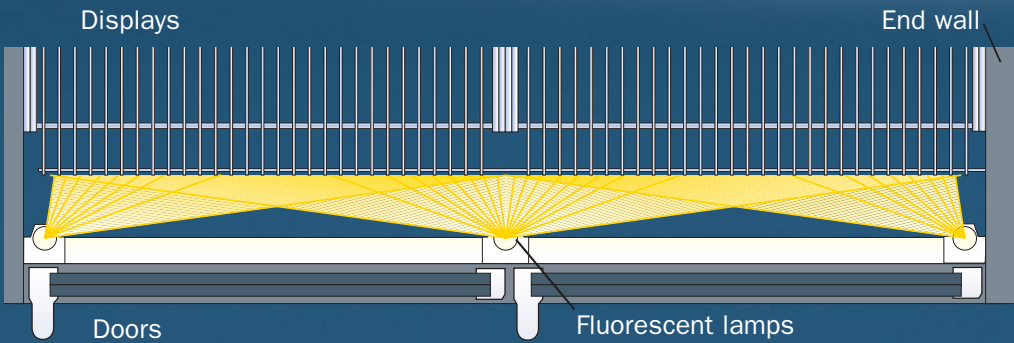

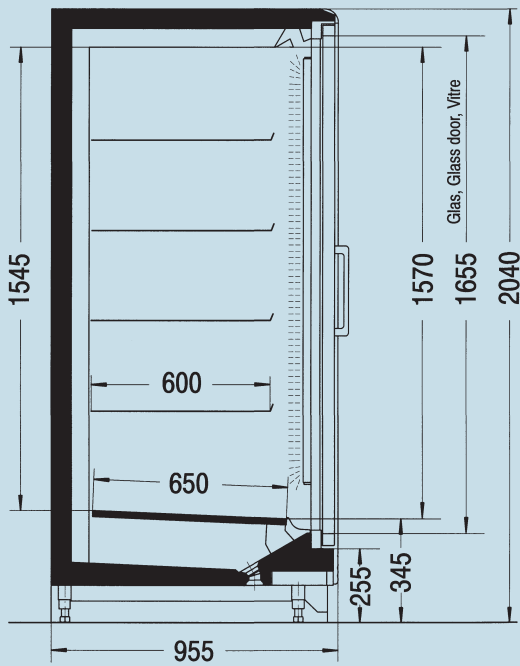

**Velando SG/AG. A8**

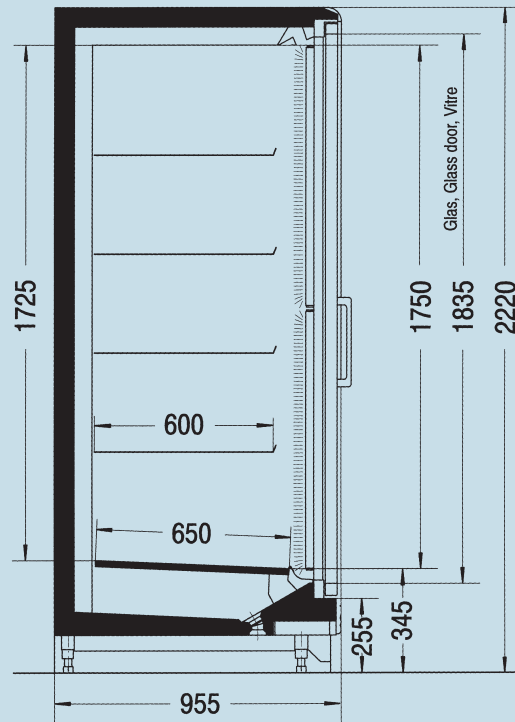

**Velando SG/AG. A8 L**

Technical data		1. Velando SG/AG. A8	2. Velando SG/AG. A8 L	2 doors	3 doors	4 doors	5 doors
Length over end walls (50 mm each)	[mm]			1665	2445	3225	4005
Temperature range	[°C]			- 18 / - 20 - 22 / - 24			
Display area	[m <sup>2</sup> ]			4.78	7.16	9.55	11.9
Net cubic capacity, litres	1.	[l]		1485	2230	2970	3710
	2.	[l]		1655	2480	3310	4130
Power supply	[V/Hz]			230 / 50			



**Evolution5**  
Made to trade.

## A new dimension captures the market

The road to the future in refrigerated display cases is signposted by Linde. With the Evolution5 Range we have entered a new dimension that lends a dynamic new look to retail merchandising: Slim-line architectural design to make way for maximum productivity per unit of floor space. Direction-setting styling that places the products in full focus. A striking color

concept wholly adaptable to any product stocking and retailing strategy. Fittings and accessories to suit every individual need. Plus energy-economizing refrigeration of peerless reliability. However a store may seek to establish its own identity and attractiveness for customers, Evolution5 starts it on the right route.

Linde Kältetechnik GmbH & Co. KG  
Sürther Hauptstrasse 173  
50999 Köln  
Germany  
Phone +49-2236-60101  
Fax +49-2236-601154  
[www.linde-refrigeration.com](http://www.linde-refrigeration.com)  
[info@linde-kt.de](mailto:info@linde-kt.de)

