



**Carrier**

A United Technologies Company

# Carucco

## Service Counters Solutions

Aesthetics  
Merchandising  
Innovation



*Linde*

# Carrier best in food Service Counters Solutions



*Willis Carrier invented modern air conditioning in 1902*



*Carl von Linde invented modern refrigeration in 1877*

More than 100 years ago, Willis Carrier invented modern air conditioning while Carl von Linde created the foundation of modern refrigeration technology.

Since then Carrier Commercial Refrigeration – in close cooperation with the largest food retail customers – acquired deep food Service Counters experience, covering all store formats and all food types. Based on this experience Carrier has launched the extensive Carucco Service Counter platform, offering Food Retailers the greatest food display combination and quality.

Carucco has been designed leveraging the most modern trends using simple and pure lines. The new style lends itself to a smooth

integration with shop architecture. As a new added value to retailers, the existing display depth dimensions of 850, 900 and 950 mm have been extended to include a new, smaller depth of 750 mm.

The Carucco platform has also been designed leveraging the latest development tools including thermodynamic and mechanical simulation in order to deliver to customers the most innovative refrigeration technology and best energy-saving solutions.



*Tegut..., a supermarket in Germany, uses Carucco counters*

# Reliability & Performance

Carrier Commercial Refrigeration Research and Development work continuously on a wide spectrum of technologies for food retail refrigeration systems and equipments. Research and Development teams are based in two world-class Lead Design Centers located in Germany and China; more than 150 engineers operate over 6,000 square meters of laboratory space that includes testing facilities, climate chambers, model workshop, physical and chemical labs and full-scale CO<sub>2</sub> refrigeration system testing facility.

Refrigerated display cabinets from Carrier are designed and qualified to the highest technical standards including refrigeration system requirements. All components go through an extensive series of qualification

tests at Carrier's Lead Design Center to ensure their reliability.

Carrier Commercial Refrigeration state-of-the-art factories strive to permanently improve products' quality and to lower their environmental impact. As part of United Technologies Corporation (UTC), Carrier is focused on technology-driven innovations and is committed to minimize environmental impact of products and processes. UTC is recognized by the U.S. Environmental Protection Agency (EPA) as a Climate Leader for its ambitious, long-term emission reduction targets. Carrier has the right refrigerant solution for every application, but every application will not have the same refrigerant solution.



Carrier Lead Design Center, Germany



Assembly line for Carrier counters, Italy

*Velocity simulation as generated by Carrier Key Competency Experts*



# Variety of merchandising solutions

A modern store's fresh food offering has developed significantly in recent years: it includes not only meat, cheese and sausages, but a wider variety of delicacies, hot food, fish, salads, pastry products, self-service for convenience and pre-packed produce. An attractive and diversified fresh food offer is crucial to awake customers' senses. This wide food offering requires a broad range of technical solutions to be presented – but a seamless appearance.

Carucco was developed according to this requirement, leveraging decades of experience: one look, but unlimited merchandising solutions. The retailer can thus select cabinets and features among the widest cabinet range available. This range includes smaller cabinets for specific areas and larger cabinets for extensive presentation with fish counters, hot food counters, pastry and frozen food specific solutions – or closed base for some areas,

and open base when the store design requires a lighter optic.

Carucco delivers best in class aesthetics, flexible solutions and attractive food presentation, realized on the same cabinet platform, with the same look.



# High-tech and aesthetic

## Ventilated – for fresh food

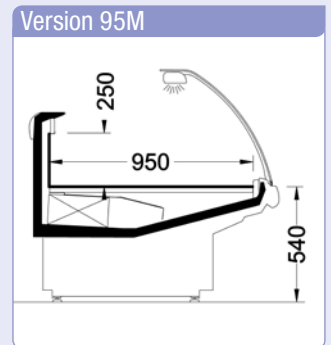
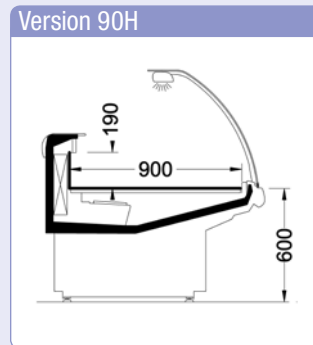
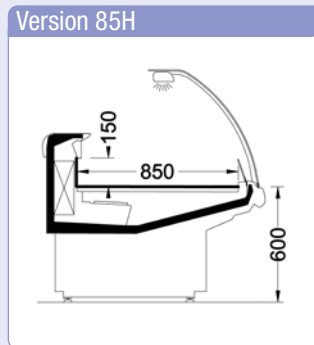
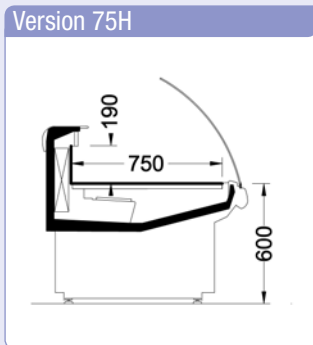

## Ventilated – for high value products

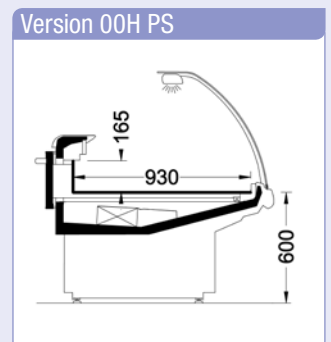
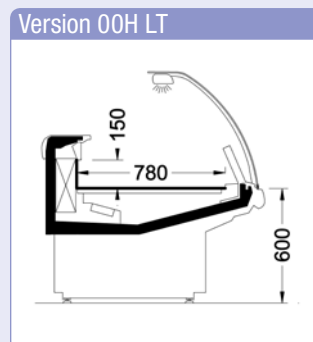
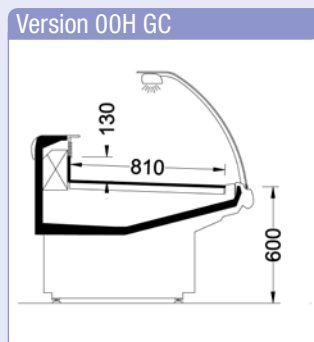
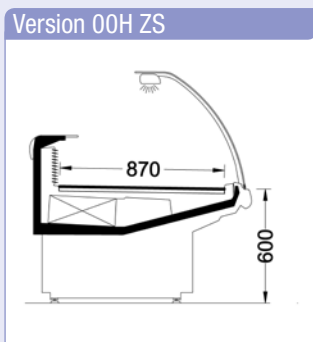

## Hot Food

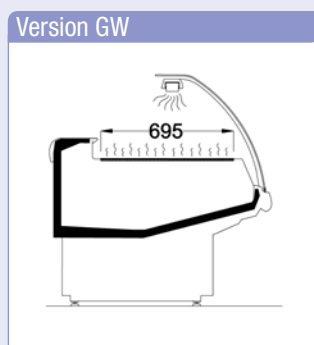
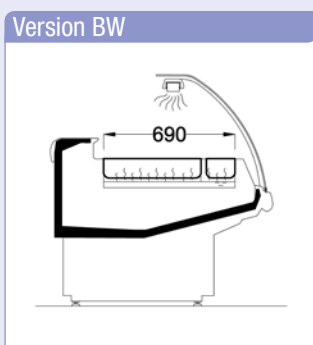

## Abbreviations

**ZS** Zeus technology, for lower product weight losses

**GC** Gravity Coil, for fish

**LT** Low temperature cabinet, for frozen food

**PS** Pastry

**BW** Hot counter, bain-marie with hot lamp

**GW** Hot counter, heated plate with hot lamp

# Competitive Carucco features

The alliance of Aesthetics, Quality, Energy savings and complete range makes the Carucco platform unique in the Refrigeration industry.

## **Aesthetics**

Carrier designed Carucco listening to its clients with the objective to make the food the star of the show.

Food Retailers expect that every customer who enters a store perceives the strong pull of an inviting service counter food presentation. The right refrigerated cabinet concept ensures prolonged freshness and enhanced product attractiveness.

These requirements plus modern design trends are part of Carucco's platform foundations.

## **Quality**

Visible quality already becomes apparent with best in class design. Its aesthetic design is inherently impressive but at the same time puts the product to the fore. The cabinet surfaces that require cleaning are easy to reach in order not only to guarantee hygiene but also deliver a sanitary look.

Material selection also plays an important role. In continuous operation the individual components have to resist the severest strain whilst at the same time meet high visual demands.

Progressive ergonomics enable longer working hours without fatigue for store staff – an indirect sales benefit.

## **Energy savings**

Carrier's motivation is not only to act with the focus on economic aspects. Carrier Commercial Refrigeration's new solutions include significant reductions in the consumption of energy, whilst maintaining a consistently high performance. All efforts made in this direction pay off, since they lead to exemplary consumption values. Saving energy reduces operating costs and takes care of the environment, built on high-performance fans and fan speed control. Developments include a new control unit that drives the performance



characteristics of the overall unit to ensure efficient operation.

In order to generate energy-saving potential on several levels, fundamental innovations are required. Carrier products are provided with a revolutionary, energy-saving refrigeration system. The new control unit regulates refrigeration depending on the ambient temperature. Since the temperature is automatically kept at the same level, a continuous operation on the highest power level is no longer required.

All Carucco counters are equipped with demisting front ventilation. These fans are installed outside at the bottom edge of the glass surface and combine

two advantages: they contribute to the reduction of the energy consumption and prevent the formation of condensation.

The control of the air flow speed also results in positive effects: speed increases when the temperature rises in order to keep the required refrigeration level. When this level is reached, speed decreases again. This does not only result in a reduction of the current consumption but also keeps the products fresh for a longer time, since less humidity is withdrawn.

#### **Complete range**

A selection of more than 120 basic modules allows the Carucco platform to deliver the smallest details to the customers.

An exact definition of demand combined with the fine feel for changes in the consumers' attitude has only one goal: creating competitive advantages for store operators. These advantages can be realized on multiple levels and guarantee permanently higher sales. On the consumers' part, visible product quality and appealing aesthetics have a positive effect on buying behavior. Improved ergonomics and easy handling increase the motivation of the sales personnel. Furthermore, the excellent energy efficiency results in a reduction of the operating costs.



# Unique Carucco selling points

## Adjustable pedestals

They are the foundation for the perfect aesthetics of an open cabinet design not impaired by visible wiring or piping. By using the adjusting mechanism, the pedestals can be set in the optimum position, depending on the respective demand. The maximum carrying capacity has also been considered here; even when the pedestals are located at the extreme outer position, the weight loading in the middle remains unchanged.

## Reduced display depth

A reduced display depth for supermarkets provides optimum ergonomics to enhance both sales activities and cleaning.

## Chrome-plated supports

The supports are delivered with lighting beams and a rear wall made of polished stainless steel – details which have a strong impact. Due to the optical mirror effect the visibility of the product is enhanced further.



*Folding fan panel for easy cleaning*



*Easy access for easy maintenance*



*Easy access to expansion valve and fans for quick maintenance*



*Thorough material selection and best fit and finish*



*Demisting by energy-saving front ventilation*



*Mirror effect for strong optical impression*



*Padded "tummy bumper" profile for improved ergonomic operation*



*Solar thermometer*



*New automatic control system*

### Modular Refrigeration System (MRS)

Constant humidity and thus best product conservation is ensured by using MRS. The display shelf is chilled to conserve products by direct contact. Air delivery fans are aerodynamic and distribute the air evenly. At the same time the air speed is controlled to give the best balance of temperature and relative humidity (RH).

### The Carucco range's numerous innovations

- Adjustable counter bases for the integration of control units, wiring and piping
- Display depths of 850, 900 and 950 mm
- Reduced display depth of 750 mm for ideal ergonomics
- Chrome-plated supports with lighting beams



Four depths available from 750 – 950 mm

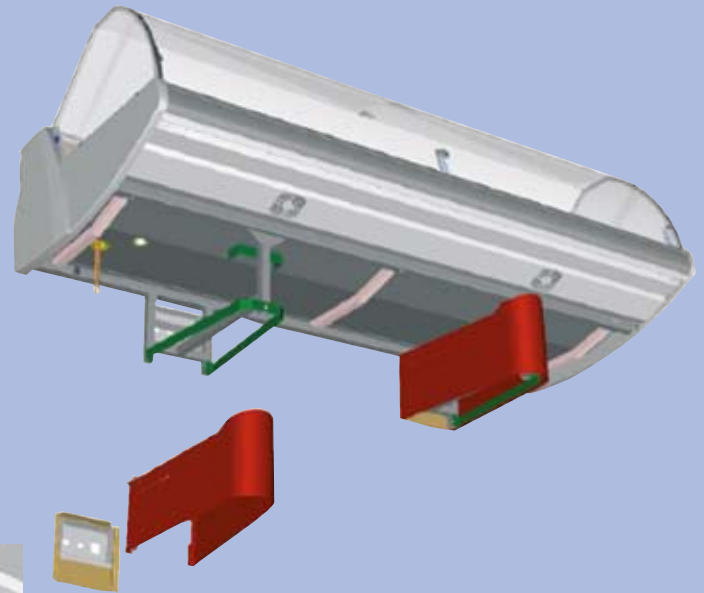

Unique mechanism for adjusting pedestals

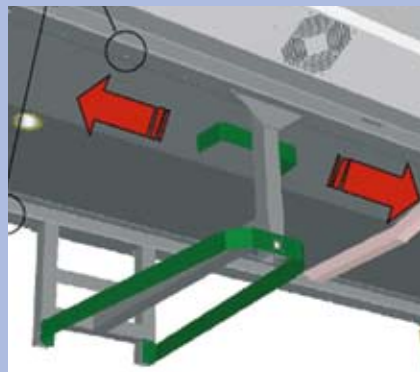

# HERA

## The beauty of transparency

### Transparency

Transparency improves trust. Attaining transparency means preferring solutions and materials that fully display the fresh products and where possible avoid solutions that conceal them.

### Product display

What does a consumer look for in a store? The product. First of all the refrigerating cabinet must enhance the fresh products and make them appealing to the consumer.

### Visibility

The product must be easily visible from all view points. This means reducing to a

minimum all cabinet components that may conceal the fresh product and increasing the product's visibility to the maximum.

### Great new look

Good taste evolves. Carrier Commercial Refrigeration has interpreted this evolution through design made of new and simple lines that can easily become integrated in the architecture of modern stores.

### Customization

Different stores and different fresh products require varying accessories with customized solutions. A horizontal display may be necessary, or sometimes slightly inclined or

on levels through a "step" display. A more rational display can be obtained by plexi-glass dividers. It may be necessary to customize some parts of the cabinet or protect the cabinet with an additional bumper rail.

### Care of details

Knowing how the operator uses the cabinet on a daily basis has helped Carrier Commercial Refrigeration to integrate new functions in each component. For example in the "tummy bumper" profile, which is now made from a flexible plastic material. In the front insulating profile, a solar cell thermometer has been built in, as well as the price holder piece.

### Modularity

One model with a thousand different solutions. That's because Carrier Commercial Refrigeration's clients always want to display various fresh products in various stores. Sometimes refrigerated cabinets are needed, in other cases heated cabinets are preferred. A modular design makes these solutions immediately available.



# Product overview

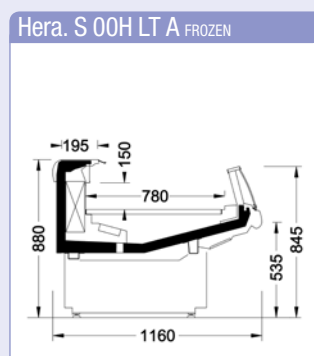
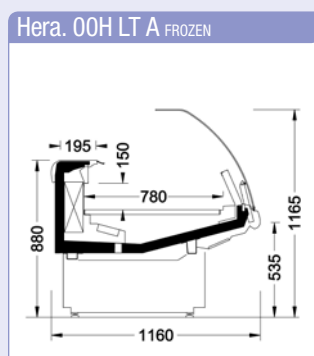
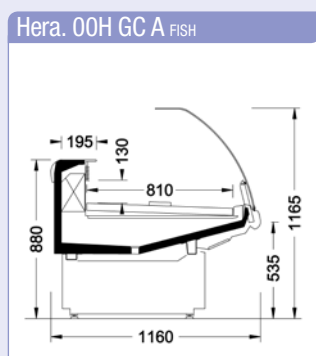
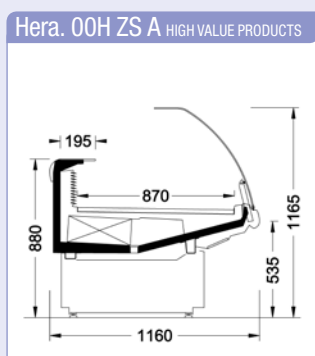
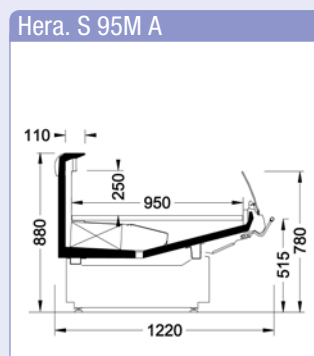
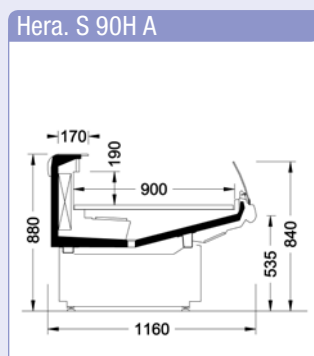
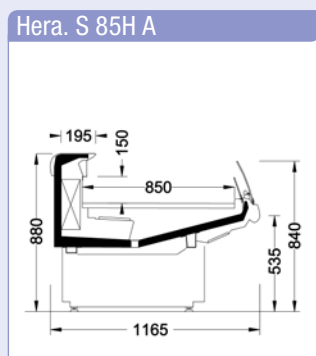
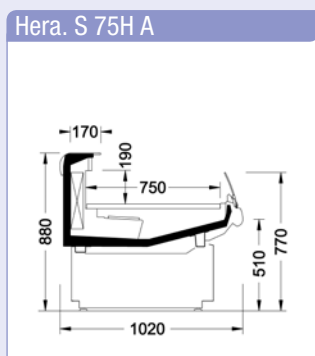
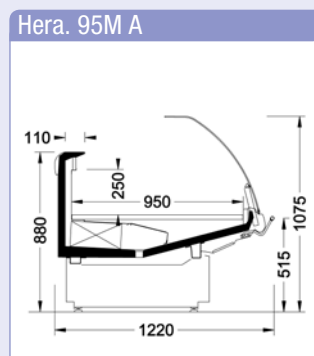
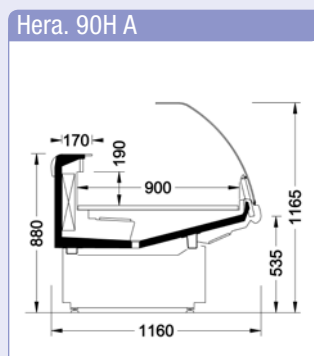
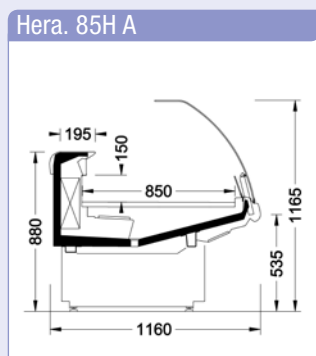
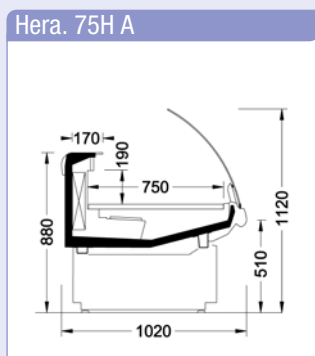

Hera	Modules												
	63	94	125	156	188	250	312	375	EC45	EC90	IC45	IC90	CE*
	Total display area (m²)												
Hera. 75H A	-	-	0.94	-	1.41	1.88	-	2.81	-	-	-	-	1.41
Hera. 85H A	0.53	0.80	1.06	1.30	1.59	2.13	2.66	3.19	0.98	1.60	1.09	2.18	-
Hera. 90H A	0.57	0.84	1.13	1.41	1.69	2.25	2.81	3.38	1.04	1.70	1.16	2.32	1.98
Hera. 95M A	-	0.89	1.18	1.48	1.77	2.37	2.95	3.54	1.08	1.76	1.25	2.50	2.09
Hera. 00H ZS A	-	-	1.09	-	1.63	2.17	-	3.26	1.01	1.64	1.14	2.28	-
Hera. 00H GC A	-	-	1.00	-	1.50	2.00	-	3.00	-	-	-	-	-
Hera. 00H LT A	-	-	0.98	-	1.46	1.95	-	2.93	-	-	-	-	-
Temperature range** (°C)					0/+2	+2/+4	+4/+6	-18/-20	-22/-24				

\* Crown End available for self service version

\*\* These temperature ranges are shown in general for the refrigerated cabinets.

# APOLLO

## Enhancing appetizing products

### Transparency

Transparency improves trust. Attaining transparency means preferring solutions and materials that fully display the fresh products and possibly avoid solutions that conceal them.

### Product display

What does a consumer look for in a store? The product. First of all the refrigerating cabinet must enhance the fresh products and make them appealing for the consumer.

### Visibility

The product must be easily visible from all points of view. This means reducing to a

minimum all cabinet components that may conceal the fresh product and increasing the product's visibility to the maximum.

### Great new look

Good taste evolves. Carrier Commercial Refrigeration has interpreted this evolution through design made of new and simple lines that can easily become integrated in the architecture of modern stores.

### Care of details

Knowing how the operator uses the cabinet on a daily basis has helped Carrier Commercial Refrigeration to integrate new functions in each component. For example

in the "belly bumper" profile, which is now made from a flexible plastic material. In the front insulating profile, a solar cell thermometer has been built in, as well as the price holder piece.

### Modularity

One model with a thousand different solutions. That's because Carrier Commercial Refrigeration's clients always want to display various fresh products in various stores. Sometimes refrigerated cabinets are needed, in other cases heating cabinets are preferred. A modular design makes these solutions immediately available.



# Product overview

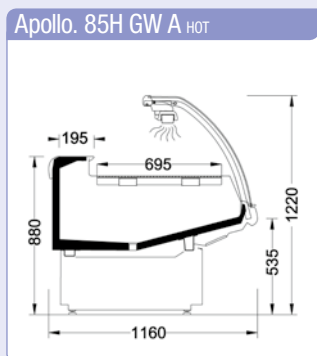
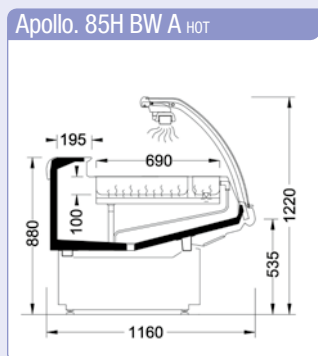
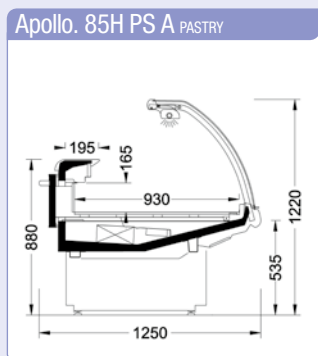
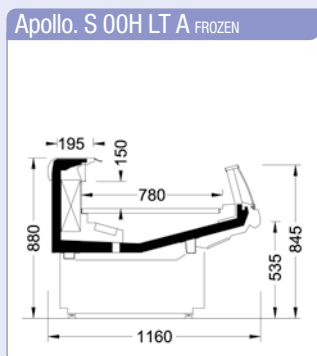
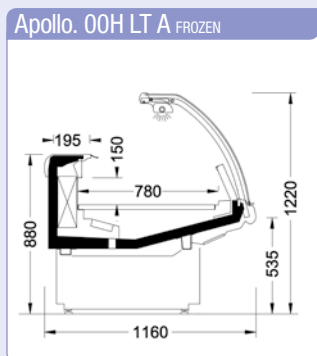
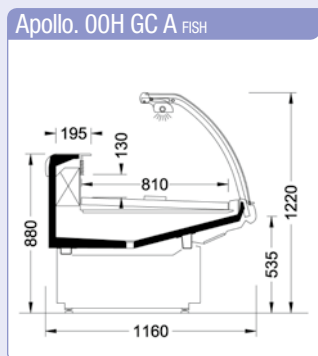
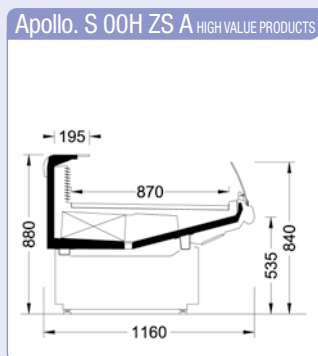
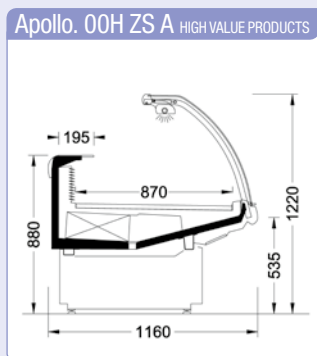
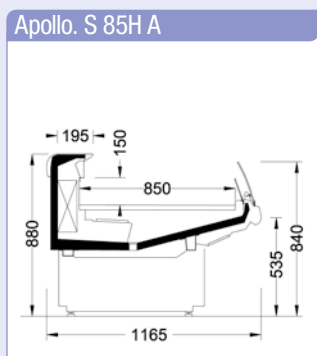
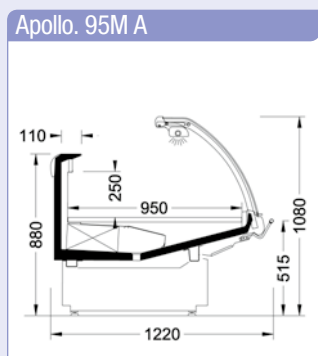
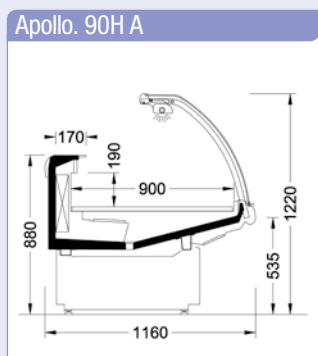
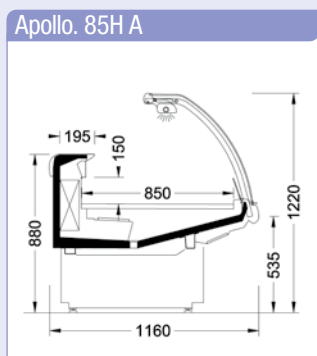

Apollo	Modules												
	63	94	125	156	188	250	312	375	EC45	EC90	IC45	IC90	CE*
	Total display area (m²)												
Apollo. 85H A	0.53	0.80	1.06	1.30	1.59	2.13	2.66	3.19	0.98	1.60	1.09	2.18	-
Apollo. 90H A	0.57	0.84	1.13	1.41	1.69	2.25	2.81	3.38	1.04	1.70	1.16	2.32	1.98
Apollo. 95M A	-	0.89	1.18	1.48	1.77	2.37	2.95	3.54	1.08	1.76	1.25	2.50	2.09
Apollo. 00H ZS A	-	-	1.09	-	1.63	2.17	-	3.26	1.01	1.64	1.14	2.28	-
Apollo. 00H GC A	-	-	1.00	-	1.50	2.00	-	3.00	-	-	-	-	-
Apollo. 00H LT A	-	-	0.98	-	1.46	1.95	-	2.93	-	-	-	-	-
Apollo. 85H/90H PS A	-	-	1.16	-	-	2.32	-	3.48	-	-	-	-	-
Apollo. 85H/90H/95M BW A	-	0.50	0.71	-	-	-	-	-	-	-	-	-	-
Apollo. 85H/90H/95M GW A	-	0.54	0.78	-	-	-	-	-	-	-	-	-	-
Temperature range** (°C)					0/+2	+2/+4	+4/+6	-18/-20	-22/-24				

\* Crown End available for self service version

\*\* These temperature ranges are shown in general for the refrigerated cabinets.

Please refer to the technical manual to match the right temperature range to the different versions.

# THETIS

## Modern presentation

### Product display

What does a consumer look for in a store? The product. First of all the refrigerating cabinet must enhance the fresh products and make them appealing for the consumer.

### Visibility

The product must be easily visible from all points of view. This means reducing to a minimum all cabinet components that may conceal the fresh product and increasing the product's visibility to the maximum.

### Great new look

Good taste evolves. Carrier Commercial Refrigeration has interpreted this evolution through design made of new and simple lines that can easily become integrated in the architecture of modern stores.

### Customization

Various stores and various fresh products require various accessories with various customized solutions. A horizontal display may be necessary, or sometimes slightly inclined or on levels through a "step" display. A more rational display can be obtained by plexi-glass dividers. It may be necessary to customize some parts of the cabinet or protect the cabinet with an additional bumper rail.

### Modularity

One model with a thousand different solutions. That's because Carrier Commercial Refrigeration's clients always want to display various fresh products in various stores. Sometimes ventilated refrigeration is needed, in other cases static

refrigeration is preferred, like for fresh fish for example. A modular design makes these solutions immediately available.

### Energy

The full life cycle Energy cost for cabinet operation can exceed the purchasing cost of the cabinet itself.

Reducing the energy consumption means reducing its environment impact, as well as greatly reducing management costs. Carrier Commercial Refrigeration has adopted high quality solutions, such as high efficiency fans and elimination of anti-mist heaters.



# Product overview

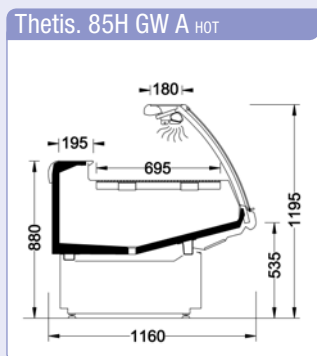
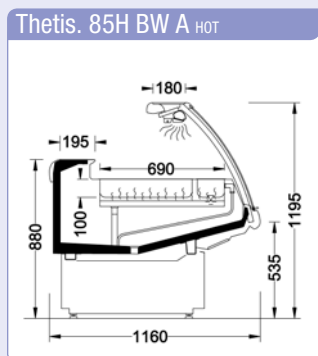
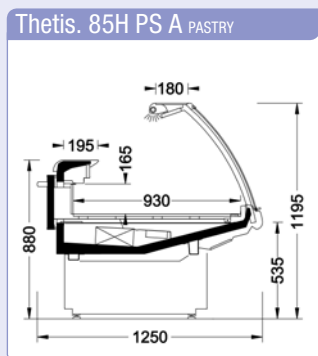
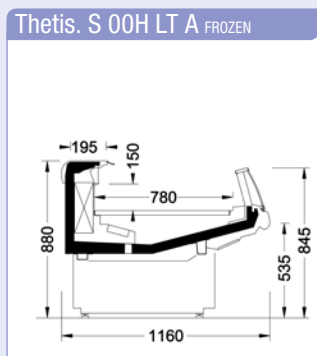
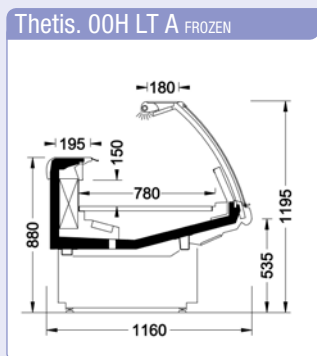
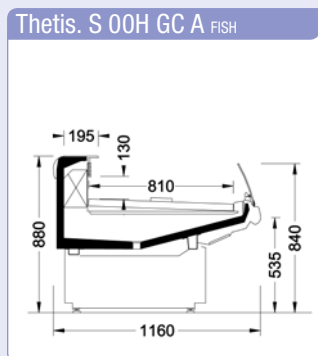
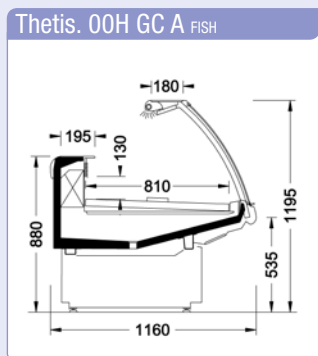
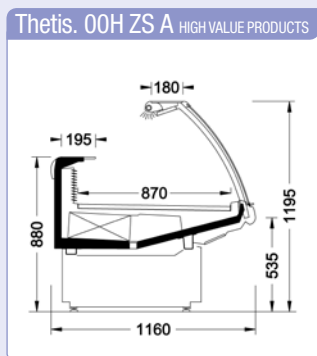
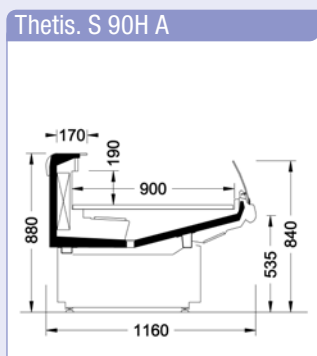
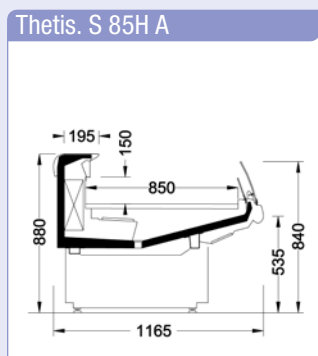
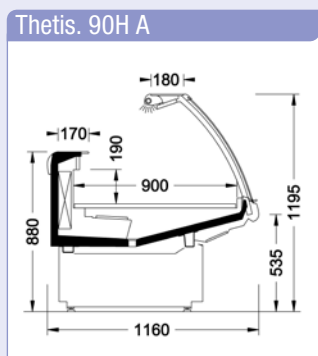
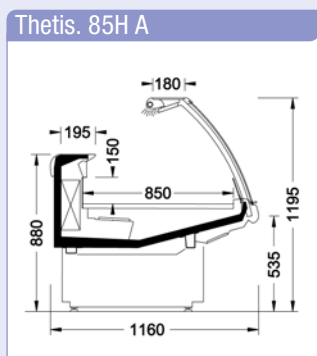

Thetis	Modules												
	63	94	125	156	188	250	312	375	EC45	EC90	IC45	IC90	CE*
	Total display area (m <sup>2</sup> )												
Thetis. 85H A	0.53	0.80	1.06	1.30	1.59	2.13	2.66	3.19	0.98	1.60	1.09	2.18	-
Thetis. 90H A	0.57	0.84	1.13	1.41	1.69	2.25	2.81	3.38	1.04	1.70	1.16	2.32	1.98
Thetis. 00H ZS A	-	-	1.09	-	1.63	2.17	-	3.26	1.01	1.64	1.14	2.28	-
Thetis. 00H GC A	-	-	1.00	-	1.50	2.00	-	3.00	-	-	-	-	-
Thetis. 00H LT A	-	-	0.98	-	1.46	1.95	-	2.93	-	-	-	-	-
Thetis. 85H/90H PS A	-	-	1.16	-	-	2.32	-	3.48	-	-	-	-	-
Thetis. 85H/90H BW A	-	0.50	0.71	-	-	-	-	-	-	-	-	-	-
Thetis. 85H/90H GW A	-	0.54	0.78	-	-	-	-	-	-	-	-	-	-
Temperature range** (°C)					0/+2	+2/+4	+4/+6	-18/-20	-22/-24				

\* Crown End available for self version

\*\* These temperature ranges are shown in general for the refrigerated cabinets. Please refer to the technical manual to match the right temperature range to the different versions.

# SELENE

## Customized aesthetics

### Visibility

The product must be easily visible from everywhere. This means reducing to a minimum all cabinet components that may conceal the fresh product and increasing the product's visibility to the maximum.

### Product display

What does a customer look for in a store? The product. First of all the refrigerating cabinet must enhance the fresh products and make them appealing to the consumer. The front glass support placed on the back reduce to a minimum the components between the consumer eyes and the fresh products.

### Careful choice of material

The refrigerated cabinet must operate for many years. Therefore materials must be selected to ensure operational longevity and temperature reliability during the entirety of the lifespan.

### Customization

Various stores and various fresh products require various accessories with various customized solutions. A horizontal display may be necessary, or sometimes slightly inclined or on levels through a "step" display. A more rational display can be obtained by plexi-glass dividers. It may be necessary to customize some parts of the cabinet

or protect the cabinet with an additional bumper rail.

### Energy

The Energy cost for cabinet operation during the whole life cycle can exceed the purchasing cost of the cabinet itself. Reducing the energy consumption means reducing the environment impact, as well as greatly reducing management costs.

Carrier Commercial Refrigeration has adopted high quality solutions, such as high efficiency fans and elimination of anti-mist heaters.



# Product overview

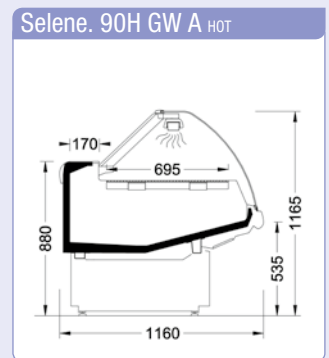
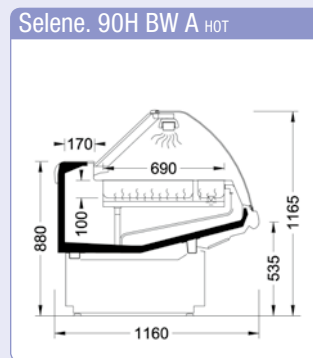
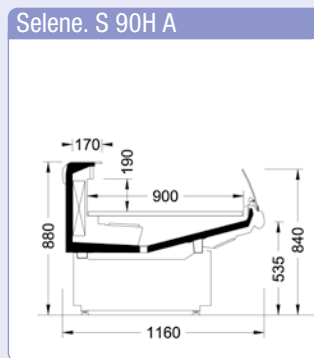
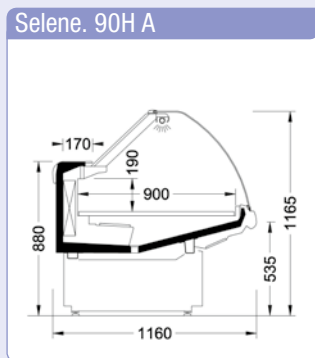

Selene	Modules												
	63	94	125	156	188	250	312	375	EC45	EC90	IC45	IC90	CE*
	Total display area (m <sup>2</sup> )												
Selene. 90H A	0.57	0.84	1.13	1.41	1.69	2.25	2.81	3.38	1.04	1.70	1.16	2.32	1.98
Selene. 90H BW A	-	0.50	0.71	-	-	-	-	-	-	-	-	-	-
Selene. 90H GW A	-	0.54	0.78	-	-	-	-	-	-	-	-	-	-
Temperature range** (°C)							0/+2	+2/+4	+4/+6				

\* Crown End available for self version

\*\* These temperature ranges are shown in general for the refrigerated cabinets.  
Please refer to the technical manual to match the right temperature range to the different versions.

# DANAOS

## High visibility

### Design & look

Good taste evolves. Carrier Commercial Refrigeration has interpreted this evolution through design made of new and simple lines that can easily become integrated in the architecture of modern stores.

### Visibility

The product must be easily visible from everywhere. This means reducing to a minimum all cabinet components that may conceal the fresh product and increasing the product's visibility to the maximum.

### Careful choice of material

The refrigerated cabinet must operate for many years. Therefore materials must be

selected to ensure operational longevity and temperature reliability during the entirety of the lifespan.

### Modularity

One model with a thousand different solutions. That's because Carrier Commercial Refrigeration's clients always want to display various fresh products, in various stores. Sometimes large displays are required, in other cases smaller cabinets are preferred. A modular design makes these solutions immediately available.

### Energy

The Energy cost for cabinet operation during the whole life cycle can exceed the

purchasing cost of the cabinet itself.

Reducing the energy consumption means reducing the environment impact, as well as greatly reducing management costs.

Carrier Commercial Refrigeration has adopted high quality solutions, such as high efficiency fans and elimination of anti-mist heaters.



# Product overview

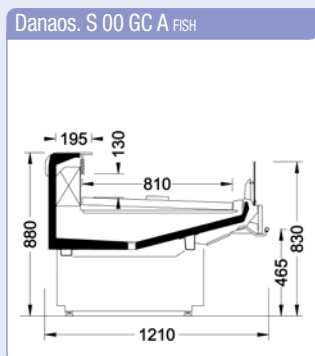
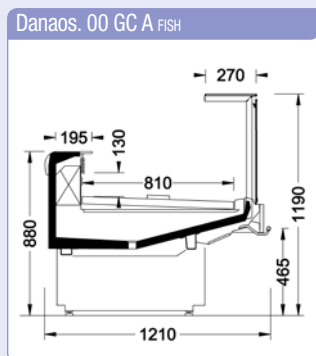
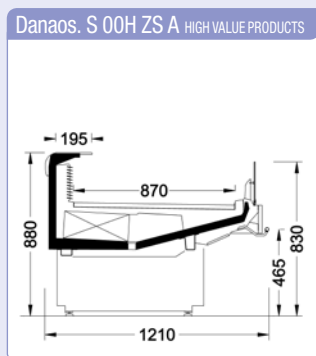
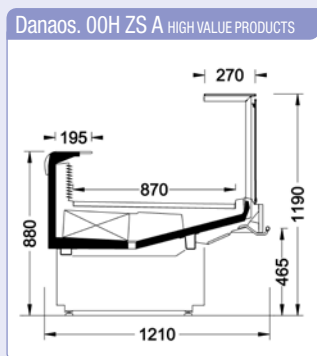
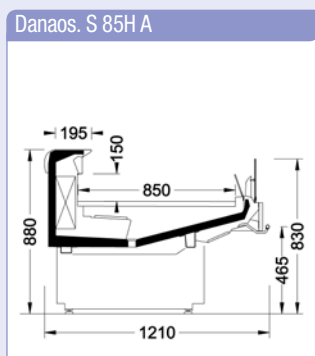
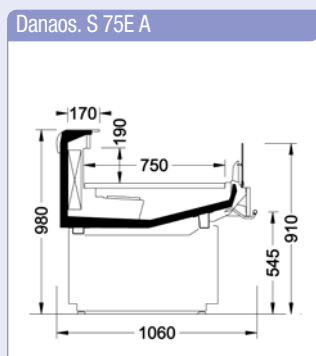
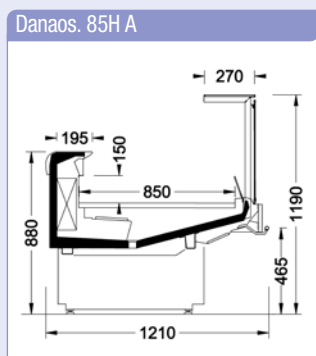
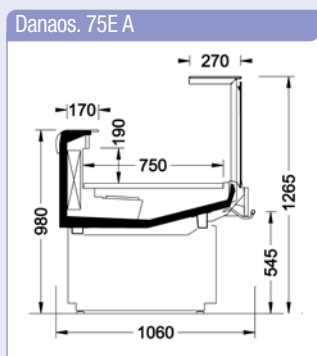

Danaos	Modules							
	125	188	250	375	EC45	EC90	IC45	IC90
	Total display area (m <sup>2</sup> )							
Danaos. 75E A	0.94	1.41	1.88	2.81	-	-	-	-
Danaos. 85H A	1.06	1.59	2.13	3.19	0.98	1.60	1.09	2.18
Danaos. 00H ZS A	1.09	1.63	2.17	3.26	1.01	1.64	1.14	2.28
Danaos. 00 GC A	1.00	1.50	2.00	3.00	-	-	-	-
Temperature range* (°C)	0/+2 +2/+4 +4/+6							

\* These temperature ranges are shown in general for the refrigerated cabinets. Please refer to the technical manual to match the right temperature range to the different versions.

# MEDEA

## Multi-level enhancement

### Transparency

Transparency improves trust. Searching for transparency means preferring solutions and materials that fully display the fresh products and where possible avoid solutions that conceal them.

### Product display

What does a consumer look for in a store? The product. First of all the refrigerating cabinet must enhance the fresh products and make them appealing for the consumer. A good refrigerated cabinet is not the key component, but the device that ensures the fresh product is always the center of attention. When necessary, the cabinet stays out of the spotlight.

### Great new look

Good taste evolves. Carrier Commercial Refrigeration has interpreted this evolution through design made of new and simple lines that can easily become integrated in the architecture of modern stores.

### Continuity of architectonic components

Modern stores ask for different technical solutions that support the different needs of efficient merchandising. A good product must meet these needs. The result must also provide aesthetic continuity.

### Customization

Various stores and various fresh products require various accessories with various

customized solutions. Sometimes internal colored shelves may be necessary with or without lighting. A more rational display can be obtained with wire dividers or in plexi-glass dividers.

### Modularity

One model with a thousand different solutions. That is because Carrier Commercial Refrigeration's clients always want to display various fresh products in various stores. Sometimes customers ask for assisted sales, sometimes for self-service sales. Sometimes they prefer more closed cabinets, sometimes more open solutions. A modular design makes these solutions immediately available.



# Product overview

Medea SD. 75H A

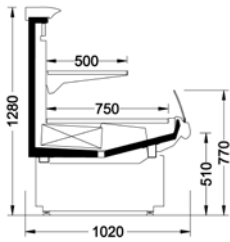

Medea ST. 75H A

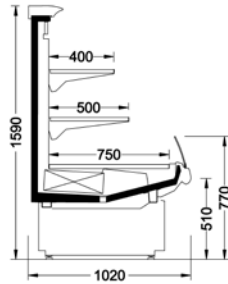

Medea SQ. 75H A

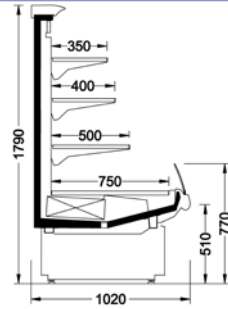

Medea SD. 90H A

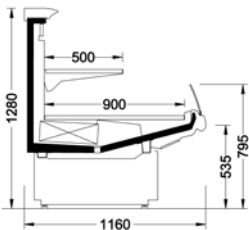

Medea ST. 90H A

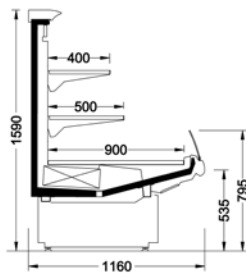

Medea SQ. 90H A

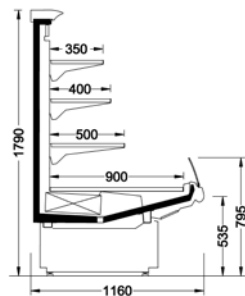

Medea SD. 90M A

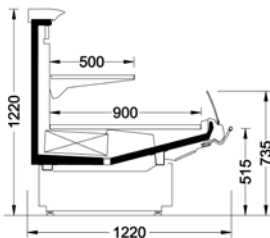

Medea ST. 90M A

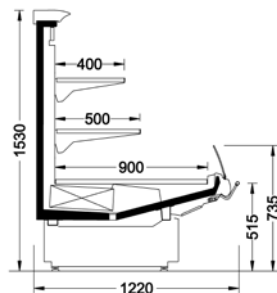

Medea SQ. 90M A

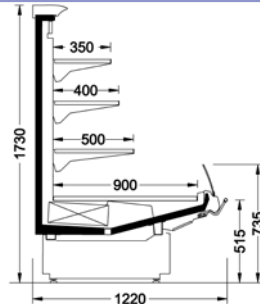

Medea	Modules				
	125	188	250	375	CE
	Total display area (m <sup>2</sup> )				
Medea SD. 75H A	1.57	2.35	3.14	4.71	2.35
Medea ST. 75H A	2.06	3.10	4.13	6.19	3.10
MedeaSQ. 75H A	2.51	3.72	5.03	7.54	3.72
Medea SD. 90H A	1.76	2.63	3.51	5.27	3.10
Medea ST. 90H A	2.25	3.38	4.50	6.75	3.98
Medea SQ. 90H A	2.70	4.00	5.40	8.10	4.75
Medea SD. 90M A	1.76	2.63	3.51	5.27	3.10
Medea ST. 90M A	2.25	3.38	4.50	6.75	3.98
Medea SQ. 90M A	2.70	4.00	5.40	8.10	4.75
Temperature range (°C)	+2/+4		+4/+6		

# Carucco range overview

## Counters

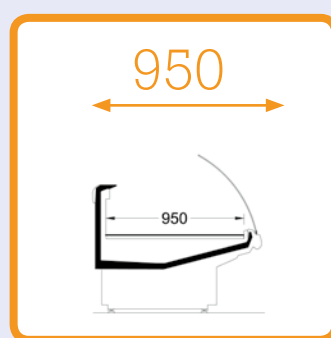
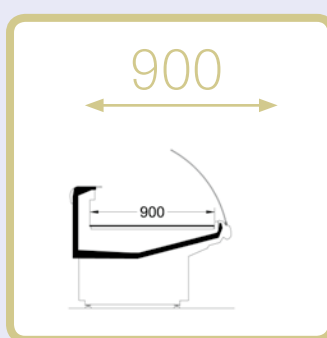
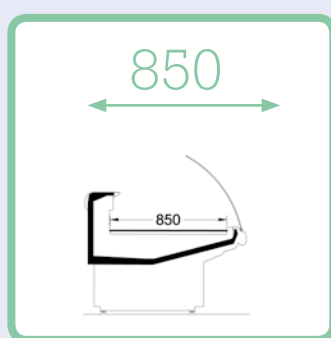
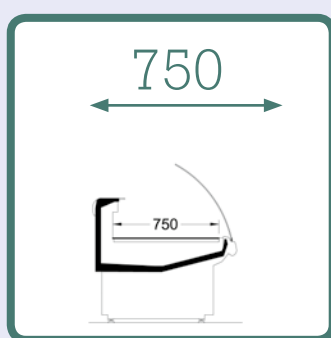
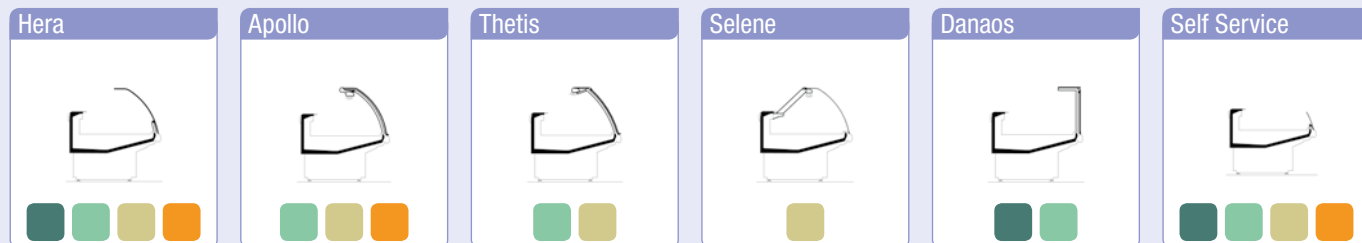

## Semi-verticals

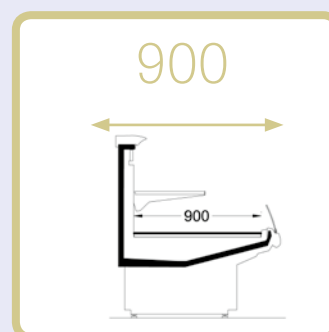
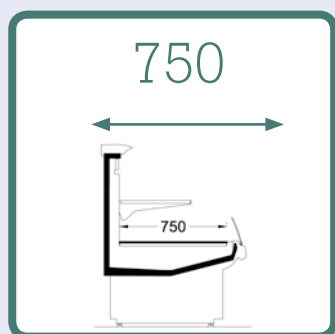
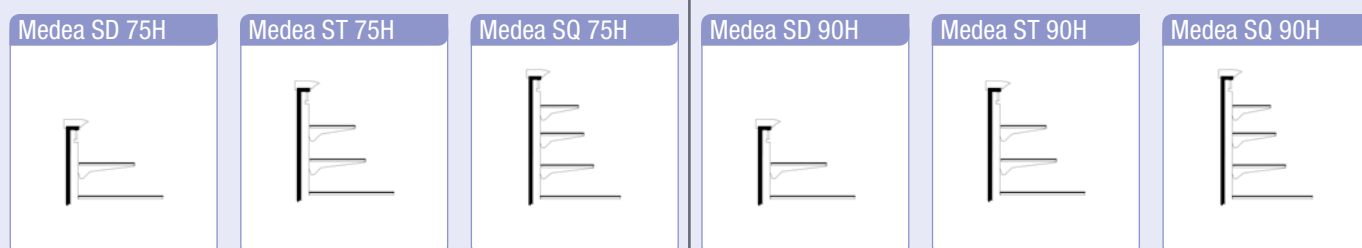

# Carrier Commercial Refrigeration offices

## Austria

Carrier Kältetechnik Austria Ges.m.b.H.  
1232 Vienna-Inzersdorf  
Phone +43 1 661 04 0

## Belgium

Carrier Refrigeration Belgium  
Branch of Carrier Refrigeration Benelux B.V.  
Molenberglei 40  
2627 Schelle  
Belgium

## China

Carrier Refrigeration System (Shanghai) Ltd.  
Shanghai 200003  
Phone +86 21 23 06 30 00

## Croatia

Carrier Kältetechnik Austria Ges.m.b.H.  
Glavna podružnica Zagreb  
10000 Zagreb  
Phone +385 1 2484 000

## Czech Republic

Carrier chladičí technika CZ s.r.o.  
190 00 Prague 9  
Phone +420 281 095 111

## Denmark

Carrier Refrigeration Denmark A/S  
8350 Hundslund  
Phone +45 86 55 02 55

## Finland

Carrier Kylmätalo Oy  
04601 Mäntsälä  
Phone +358 19 52 29 200

## France

Carrier Refrigeration Distribution France SAS  
94100 St Maur des Fossés  
Phone +33 1 43 97 61 00

## Germany

Carrier Kältetechnik Deutschland GmbH  
50999 Cologne  
Phone +49 2236 601 01

## Greece

Carrier Frigel Apostolou SA  
10442 Athens  
Phone +30 210 5763950

## Hong Kong

Carrier Hong Kong Ltd.  
Kowloon  
Phone +852 26 94 53 33

## Hungary

Carrier Hätéstechnika Forgalmazó  
Magyarország Kft./Carrier Refrigeration  
Distribution Hungary Ltd.  
1037 Budapest  
Phone +36 1 437 05 10

## India

Carrier Airconditioning and Refrigeration Ltd.  
Gurgaon, Harayana 122001  
Phone +91 124 482 55 00

## Ireland

Carrier Refrigeration Ireland  
a branch of Carrier UK Ltd  
Dublin 24  
Phone +353 1 451 5585

## Italy

Carrier Refrigeration Distribution Italy SpA  
20090 Buccinasco (Milan)  
Phone +39 02 488 675 1

## Korea

Carrier Refrigeration Korea  
Youngdeungpo-gu, Seoul  
Phone +82 2 20 71 51 03

## Malaysia

Carrier (Malaysia) Sdn. Bhd.  
47610 Subang Jaya, Selangor Darul Ehsan  
Phone +603 802 47 77 88

## Middle East

Linde Kältetechnik GmbH  
(Carrier Commercial Refrigeration)  
Dubai – United Arab Emirates  
Phone +971 4 222 5216

## Netherlands

Carrier Refrigeration Benelux B.V.  
4104 AW Culemborg  
Phone +31 345 544 444

## Norway

Carrier Refrigeration Norway AS  
0668 Oslo  
Phone +47 23 37 58 40

## Philippines

Carrier Linde Refrigeration Phils., Inc.  
Alabang, Muntinlupa City  
Phone +632 775 06 30

## Poland

Carrier Chłodnictwo Polska Sp. z o.o.  
02-676 Warsaw  
Phone +48 22 54 40 100

## Russia

Carrier Refrigeration Rus  
109240 Moscow  
Phone +7 495 933 11 75

## Singapore

Carrier Singapore (Pte) Ltd.  
Singapore 608926  
Phone +65 65 67 55 22

## Slovakia

Carrier chladiaca technika Slovakia s.r.o.  
949 07 Nitra  
Phone +421 377 764 011

## Slovenia

Carrier Kältetechnik Austria Ges.m.b.H. –  
Podružnica Ljubljana  
1000 Ljubljana  
Phone +386 1 2425 523

## Spain

Carrier Refrigeración Ibérica SA  
08036 Barcelona  
Phone +34 93 4527 184

## Sweden

Carrier Refrigeration Sweden AB  
213 76 Malmö  
Phone +46 40 664 51 70

## Switzerland

Carrier Kältetechnik Schweiz AG  
4133 Pratteln  
Phone +41 61 816 66 66

## Taiwan

Carrier Transicold Pte Taiwan Branch  
Taipei  
Phone +886 2 28 81 18 00

## Thailand

Carrier Linde Refrigeration (Thailand) Ltd.  
Bangkok 10510  
Phone +66 25 17 20 00

## United Kingdom

Carrier Refrigeration UK Ltd.  
Oxford OX4 6HQ  
Phone +44 1 865 337 700



## think system - master energy

Smart systems use energy wisely, where needed, when required. Based on this understanding we offer solutions combining energy, efficiency and ecology. This stands for energy savings over the entire life cycle, sustainable performance in temperature quality and food safety, and significant carbon footprint reduction. This is where we focus our energy. Increased sales are one of the benefits for our customers. We provide more: sustainable, state-of-the-art refrigeration solutions.

Carrier Commercial Refrigeration is a leading supplier of high efficiency turnkey refrigeration systems and services in the food retail industry. Contact one of our local offices to discover our complete range of products and services offering on: [www.carrier-refrigeration.de](http://www.carrier-refrigeration.de)

-  CO<sub>2</sub> Cooling Systems
-  HFC Cooling Systems
-  Applications, Cooling Systems
-  Condensers, Cooling Systems
-  Control Cooling Systems
-  Counters, Multidecks, Semi-verticals, Roll-in cabinets and Ultrafreshness
-  Islands, Wall-sited cases and Vertical freezers
-  Plug-in cases
-  Services



**Carrier**

A United Technologies Company